

HYDRONIC L

Troubleshooting and Repair Instructions

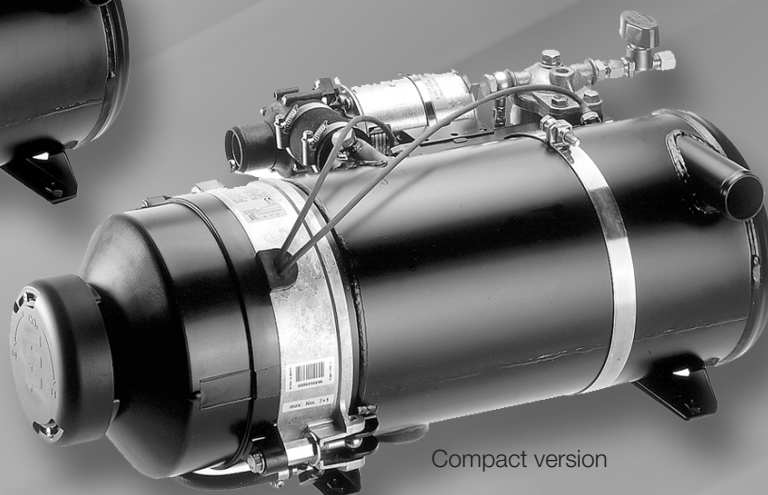

Normal version



Compact version

Normal version

Hydronic 16 – 24 Volt
 Hydronic 24 – 24 Volt
 Hydronic 30 – 24 Volt
 Hydronic 35 – 24 Volt

Order No.:

25 2165 02 00 00
 25 1817 02 00 00
 25 1818 02 00 00
 25 1819 02 00 00

Basic unit No.:

25 2165 01 00 00
 25 1817 01 00 00
 25 1818 01 00 00
 25 1819 01 00 00

Compact version

Hydronic 24 – 24 Volt
 Hydronic 30 – 24 Volt
 Hydronic 35 – 24 Volt

Order No.:

25 1817 05 00 00
 25 1818 05 00 00
 25 2041 05 00 00

Basic unit No.:

25 1817 01 00 00
 25 1818 01 00 00
 25 1819 01 00 00

**Water heaters for diesel fuel, operating
 perating independently of an engine.**

1 Introduction

Contents

This list of contents provides precise information about the contents of these Troubleshooting and Repair Instructions.

If you are looking for a specific term, use the index at the end of this document.

Chapter	Title	Contents	Page
1	Introduction	<ul style="list-style-type: none"> • Contents 2 – 3 • Foreword 4 • Safety instructions for installation and repair 4 • Accident prevention 4 • Special text structure, presentation and picture symbols 4 • Important information before starting work 4 	
2	Function	<ul style="list-style-type: none"> • Cutaway view 5 • Structure of the heater 6 • Special features of the heater 6 • Operating instructions 6 • Description of functions 6 • Functional diagram 7 • Control diagram 7 • Control and safety devices 8 • Emergency stop (EMERGENCY OFF) 8 	
3	Product information	<ul style="list-style-type: none"> • Technical data, heater 9 • Technical data, water pump 10 – Pumping and pressure loss characteristic curves 10 	
4	Troubleshooting	<ul style="list-style-type: none"> • What to check first in case of faults 11 • Locking the control box 11 • Cancelling the control box lock 11 • Fault diagnosis – flashing code 12 • Overview of the individual test equipment and control units 13 • External diagnostic system 13 • Fault diagnosis using the diagnostic unit 14, 15 • Fault diagnosis: EDiTH customer service program with ISO adapter 16 • Fault diagnosis: EDiTH customer service program with basic adapter 17 • Fault diagnosis using the module timer 18 • Fault diagnosis using the radio remote control TP5 19 • Fault diagnosis with EasyStart R+ radio remote control and EasyStart T timer 20 • Fault code table 21 – 24 	
5	Repair instructions	<ul style="list-style-type: none"> • Repair instructions 25 • Always observe the following safety instructions before working on the heater 25 • AMP release tool 25 • Assembly drawing 26, 27 – Component parts 27 • Removing the hood 28 • Dismantling the burner 28 • Dismantling the control box 28 • Dismantling the burner motor 29 • Checking the function and speed of the burner motor using the burner tester 29 • Dismantling the ignition electrodes 30 • Dismantling the fuel nozzle 30 • Dismantling the ignition unit 31 • Testing the ignition unit using the burner tester 31 • Dismantling the solenoid valve 32 • Testing the solenoid valve using the burner tester 32 • Dismantling the nozzle block 33 – Nozzle block made of brass 33 – Functional check of the heating cartridge 33 • Dismantling the flame tube 34 	



1 Introduction

Contents

Chapter	Title	Contents	Page
5	Repair instructions	<ul style="list-style-type: none">• Dismantling the temperature and overheating sensor 35• Temperature and overheating sensor resistance values 35<ul style="list-style-type: none">– Table of characteristic values - temperature sensor 35– Temperature sensor diagram 35– Table of characteristic values - overheating sensor 36– Overheating sensor diagram 36• Dismantling the gauze fuel filter 37• Notes on the fuel flow rate and the pressure in the fuel system..... 36• Measuring the CO₂ content 37• Adjusting the combustion air 37• Dismantling the water pump (standard design) 39• "Bus 2000" water pump..... 39• Dismantling the <i>FLOWTRONIC</i> 5000 water pump 40	
6	Circuit diagrams	<ul style="list-style-type: none">• Heater circuit diagram – Part 1 (Hydronic 16 / 24 with temperature switch) 41• Heater circuit diagram – Part 1 (Hydronic 16 – 35 without temperature switch).. 42• Heater circuit diagram – Part 2 with water pump (standard design) and "Bus 2000" water pump 43• Heater circuit diagram – Part 3 with <i>FLOWTRONIC</i> water pump 44• Circuit diagram / parts list for control units..... 45, 46• Parts list for circuit diagram - EasyStart control units 47• EasyStart R control unit circuit diagram 48• EasyStart R+ control unit circuit diagram 49• EasyStart T control unit circuit diagram 50	
7	Service	<ul style="list-style-type: none">• Certification 51• Disposal 51• EC Declaration of Conformity 51• List of key words 52, 53	

1 Introduction

Foreword

These Troubleshooting and Repair Instructions are applicable to the heaters listed on the title page, to the exclusion of all liability claims.

Depending on the version or revision status of the heater, there may be differences between it and these Troubleshooting and Repair Instructions.

The user must check this before carrying out the repair work and, if necessary, take the differences into account.



Important!

Safety instructions for installation and repair!

Improper installation or repair of Eberspächer heaters can cause a fire or result poisonous exhaust entering the inside of the vehicle. This can cause serious and even fatal risks.

The heater may only be installed according to the specifications in the technical documents or repaired using original spare parts by authorised and trained persons.

Installation and repairs by unauthorised and untrained persons, repairs using non-original spare parts and without the technical documents required for installation and repair are dangerous and therefore are not permitted.

A repair may only be carried out in connection with the respective unit-related technical description, installation instructions, operating instructions and maintenance instructions. This document must be carefully read through before / during installation and repair and followed throughout. Particular attention is to be paid to the official regulations, the safety instructions and the general information.

Please note!

The relevant rules of sound engineering practice and any information provided by the vehicle manufacturer are to be observed during the installation and repair.

Eberspächer does not accept any liability for defects and damage, which are due to installation or repair by unauthorised and untrained persons.

Compliance with the official regulations and the safety instructions is prerequisite for liability claims. Failure to comply with the official regulations and safety instructions leads to exclusion of any liability of the heater manufacturer.

Accident prevention

General accident prevention regulations and the corresponding workshop and operating safety instructions are to be observed.

Special text structure, presentation and picture symbols

Special text formats and picture symbols are used in these instructions to emphasise different situations and subjects. Please refer to the following examples for their meanings and appropriate action.

Special text formats and presentations

- A dot (•) indicates a list, which is started by a heading.
 - If an indented dash (–) follows a "dot", this list is a subsection of the black dot.

Picture symbols



Danger!

This information points out a potential serious or fatal danger. Ignoring this information can result in severe injuries.



Important!

This information points out a dangerous situation for a person and / or the product. Failure to comply with these instructions can result in injuries to people and / or damage to machinery.

Important information before starting work

Initial commissioning of the heater or functional test after a repair

- After installing the heater, the whole fuel supply system must be carefully vented: please refer to and follow the vehicle manufacturer's instructions.
- During the heater trial run, all fuel connections must be checked for leaks and secure, tight fit.
- If faults occur while the heater is running, use a diagnostic unit to determine and correct the cause of the fault.



2 Function

Cutaway view

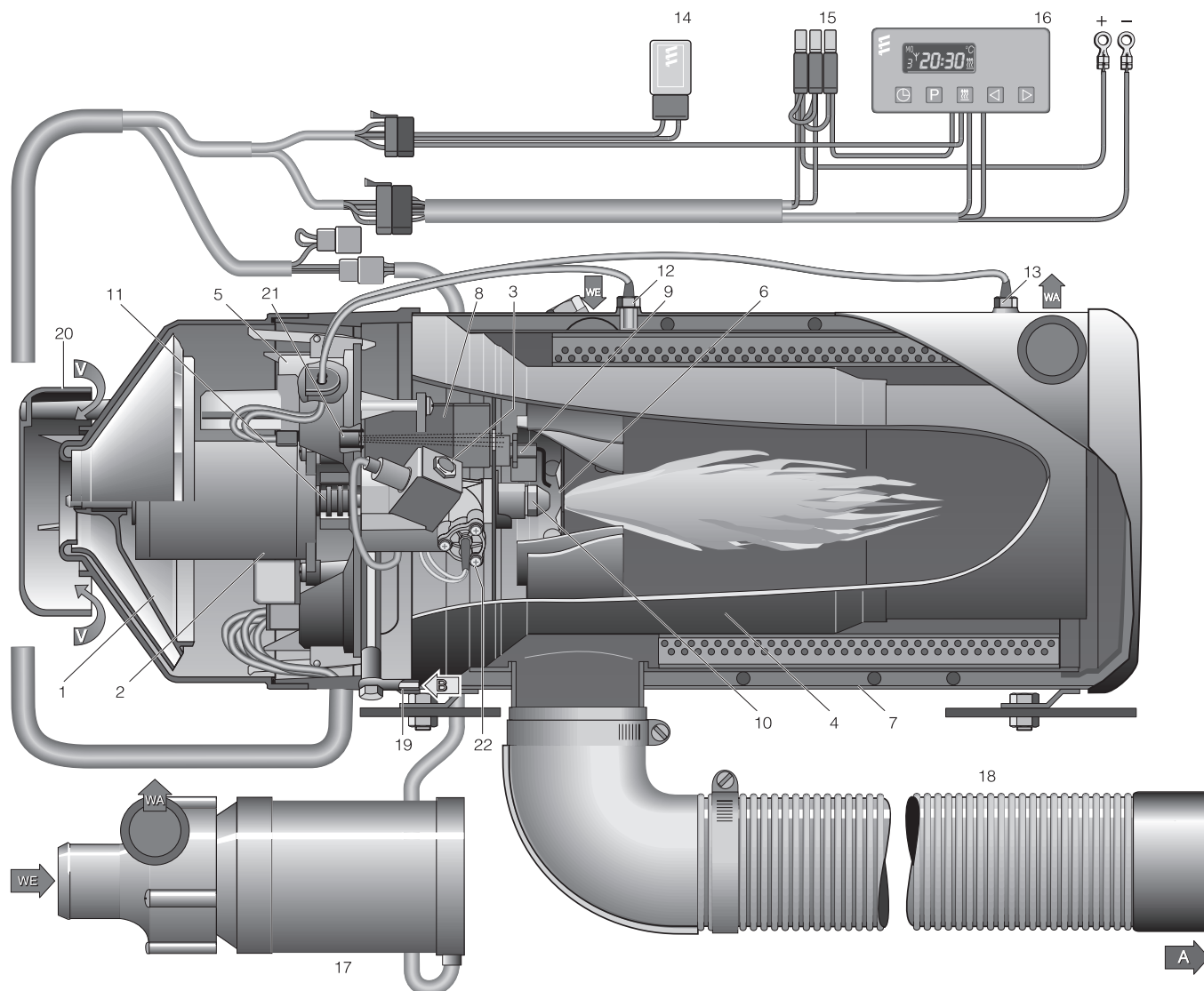

Sketch 1

- | | | | | | |
|----|---------------------|----|--|----|----------------|
| 1 | Impeller | 11 | Coupling | A | Exhaust |
| 2 | Electric motor | 12 | Temperature sensor | B | Fuel |
| 3 | Solenoid valve | 13 | Overheating sensor | V | Combustion air |
| 4 | Flame tube | 14 | Relay (vehicle blower control) | WA | Water outlet |
| 5 | Control box | 15 | Fuses | WE | Water inlet |
| 6 | Combustion chamber | 16 | Module timer | | |
| 7 | Heat exchanger | 17 | Water pump | | |
| 8 | Ignition unit | 18 | Exhaust pipe | | |
| 9 | Ignition electrodes | 19 | Fuel connection | | |
| 10 | Fuel nozzle | 20 | Hood (CO ₂ adjustment) | | |
| | | 21 | Flame detection photocell | | |
| | | 22 | Nozzle block with integrated heating element | | |

2 Function

Structure of the heater

The heater consists of a heat exchanger and a removable burner. A combustion chamber consisting of a flame tube with integrated mixer is inserted in the heat exchanger. The flame tube can be pulled out of the heat exchanger if necessary. The control box and electric motor are fixed to the burner flange under the burner hood. The fuel pump is integrated in the burner housing.

The following additional parts are required for operation of the heater:

- Water pump
- Additional parts for connection to the water circuit
- Additional parts for the fuel supply
- Additional parts for the exhaust system
- Control unit

Order No. see technical description, for further additional parts see additional parts catalogue.

Special feature of the heater

- If the water flow rate is too low, the water outlet temperature is limited by premature correction.
- The temperature rise of the heating medium is monitored over time. If it rises too fast (water flow rate too low) the heater automatically switches "OFF" and begins the after-run, the cycle then begins again.
- Constant comparison of the measured temperature sensor and overheating sensor values provides additional heater safety. If the difference between the measured values is too large (water flow rate too low) the heater prematurely switches "OFF".

Operating instructions

The heater is operated by a control unit. Detailed operating instructions are supplied with the control unit.

Please note!

The operating instructions are issued to you by the garage / workshop that installs the heater.

Description of functions

Switching on the heater

When the heater is switched on, a component test is carried out (3 seconds) and then the water pump is started up.

Note:

If the water temperature is $< 5\text{ }^{\circ}\text{C}$ the nozzle pre-heater is switched on for 60 seconds; the burner start is delayed by this length of time.

Burner start

The electric motor starts and drives the combustion air impeller and the fuel pump.

After approx. 10 seconds, the ignition is switched on and then the fuel solenoid valve opens. Within these 10 seconds a rotational check of the electric motor is carried out. The fuel and combustion air in the combustion chamber form an ignitable mixture.

The mixture is ignited by a high-voltage ignition spark. The flame detection photocell detects the flicker frequency of the flame and switches off the ignition unit. The hot fuel gases flow through the heat exchanger and transfer the heat to the heating medium.

Please note!

- The heater operates depending on the heat requirement, therefore the length of the burner's on-time and off-time periods differ.
- The water pump continues to run throughout the whole operating period, even during pause mode periods and during the after-run.

Options

- When the temperature drop is activated the "ON / OFF" control temperatures are lowered by approx. 8K. For connection of the ON / OFF switch for temperature drop, see circuit diagram on pages 43 and 44.
- The water pump can also be operated independently of the heater, if an appropriate control is installed. For connection of the additional "ON / OFF" switch for separate water pump control, see circuit diagram on pages 43 and 44.
- For vehicle blower control, the vehicle blower is switched on and off at the following water temperatures.
 - Water temperature $> 55\text{ }^{\circ}\text{C}$ —>Vehicle blower "ON"
 - Water temperature $< 50\text{ }^{\circ}\text{C}$ —>Vehicle blower "OFF"

Switching off the heater

If the heater is switched off, the fuel solenoid valve closes and at the same time the approx. 3 minute after-run begins. After the after-run has finished the heater is automatically switched off.

Please note!

Until it is switched off, including during the after-run, the fuel is circulated.



2 Function

Functional diagram

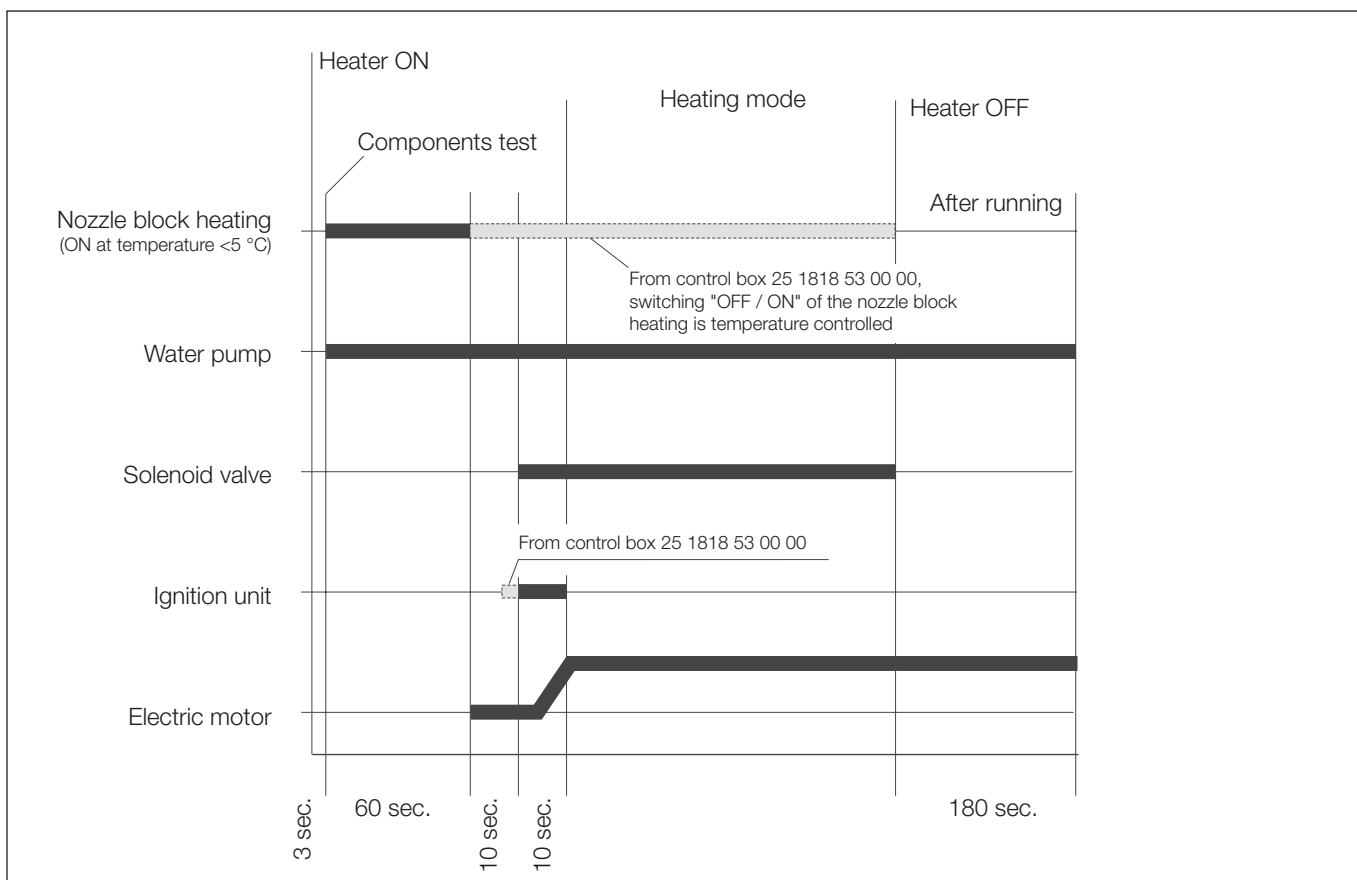

Sketch 2

Control diagram

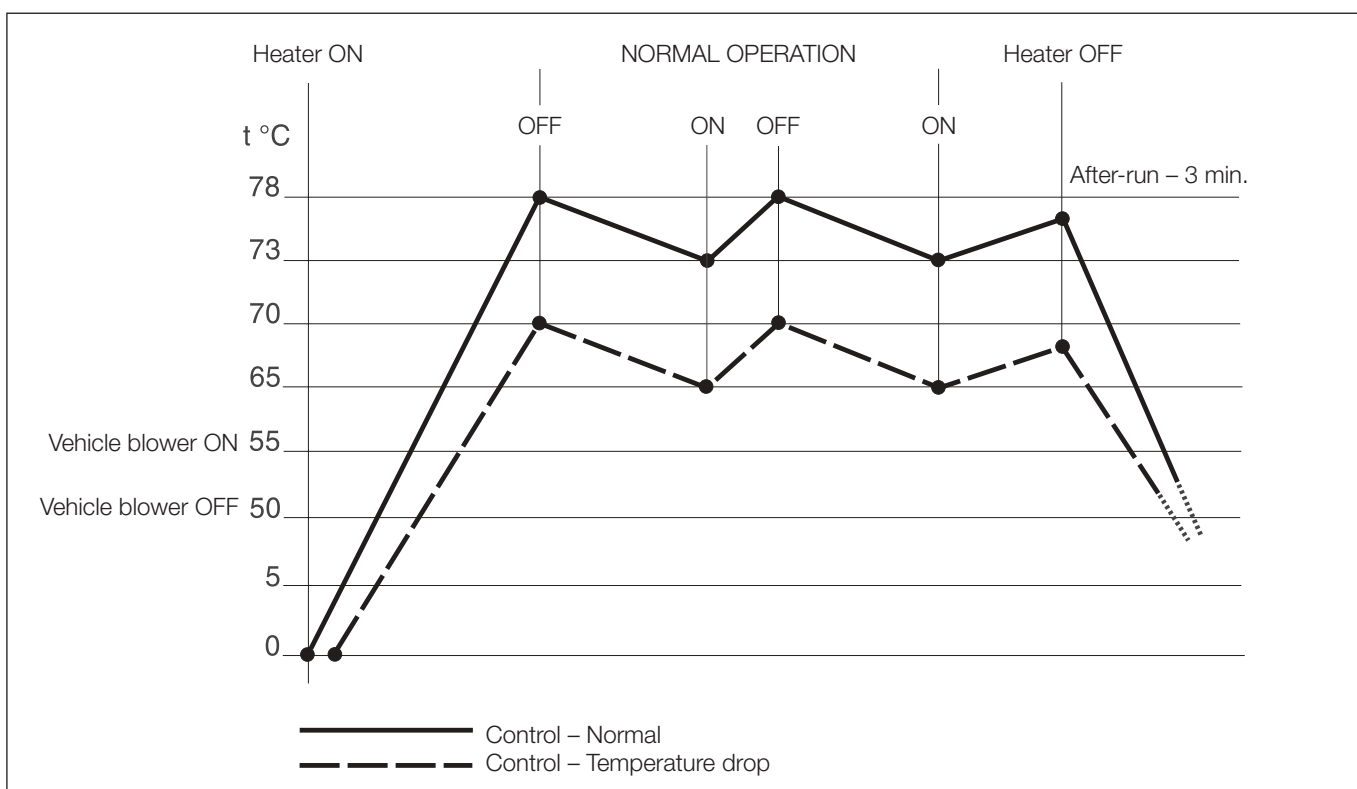

Sketch 3

2 Function

Control and safety devices

The heater is equipped with the following control and safety devices.

- If the heater does not ignite the control box* is locked after an impermissible number of failed start attempts.
 - If the water flow rate is too low, the water outlet temperature is limited by premature correction.
 - The temperature rise of the heating medium is monitored over time. If it rises too fast (water flow rate too low) the heater automatically switches "OFF" and begins the after-run, the cycle then starts again.
 - Constant comparison of the measured values for the temperature sensor and overheating sensor provides additional heater safety, as a premature lockout (shutdown on faults) occurs if the difference between the measured values is too high (the water flow rate is too low).
After an impermissible number of lockouts, the control box is locked.*
 - If the lower or upper voltage limit is reached, a lockout (shutdown on faults) occurs.
 - If the flame sensor detects a flame during the heater's after-run a lockout occurs (shutdown on faults).
After an impermissible number of lockouts, the control box is locked.*
- * The lock can be cancelled and the faults read out:
- with the module timer / EasyStart T timer
 - with the radio remote control TP5 / EasyStart R+.
- For other control units by connecting:
- the diagnostic unit
 - the customer service program KD2000 / EDiTH.
- For details of operation and fault list, see these Troubleshooting and Repair Instructions from page 13.

Emergency shutdown – EMERGENCY OFF

If an emergency shutdown – EMERGENCY OFF – is required during operation, execute the following:

- Switch the heater off at the control unit or
- remove the fuse or
- disconnect the heater from the battery.



3 Product information

Technical data, heater	Hydronic L			
	D 16 W N	D 24 W N	D 30 W N	D 35 W N
Type	Mixture of water and refrigerant (max. 50 % refrigerant fraction)			
Heating medium	Mixture of water and refrigerant (max. 50 % refrigerant fraction)			
Heat flow in watt (at ambient temperature 20 °C)	16 000	24 000	30 000	35 000
Temperature values – at water inlet	ON 73 °C / OFF 78 °C			
Temperature values – at water outlet	ON 85 °C / OFF 118 °C			
Fuel	Diesel – standard commercial (DIN EN 590) Heating oil EL (DIN 51603)			
Fuel consumption (at ambient temperature –10 °C)	2.0 l/h	2.9 l/h	3.65 l/h	4.2 l/h
Rated voltage	24 volt			
Operating range				
<ul style="list-style-type: none"> Lower voltage limit: An undervoltage protector installed in the control box switches off the heater if the voltage limit is reached. 	19 volt			
<ul style="list-style-type: none"> Upper voltage limit: An overvoltage protector (surge suppressor) installed in the control box switches off the heater if the voltage limit is reached. 	30 volt			
Electrical power consumption (in combustion mode / without circulating pump)	60 watt	80 watt	105 watt	120 watt
Water content of the heat exchanger	approx 2 l			
Water content of the water circuit	min. 10 l			
Minimum heating medium flow rate (±200 l/h)	1400 l/h	2000 l/h	2600 l/h	3000 l/h
Permissible ambient temperature	in operation: –40 °C to +85 °C during transport / storage: –40 °C to +100 °C for the combustion air: < 60 °C Pumped medium: –40 °C to +90 °C, short-term up to +120 °C			
Operating pressure (water circuit)	< 2.5 bar			
CO ₂ values (% vol)	9 – 11	9 – 11	9 – 11	9.5 – 11.5
CO in the exhaust	< 0.04			
Smoke spot no. (Bacherach)	< 4			
Weight	approx 18 kg			
Interference suppression class	VHF 4 / SW 3 / MW 5 / LW 3 according to DIN 57879 / Part 1 VDE 0879			
Protection	IP 64			



Important!

Safety instructions for technical data!

Failure to comply with the technical data can result in malfunctions.

Please note!

If no limit values are given, the technical data listed is with the usual heater tolerances of ± 10 % at nominal voltage, 20 °C ambient temperature and Esslingen reference altitude.

3 Product information

Technical data, water pump		FLOWTRONIC 5000
Heating medium	Mixture of water and refrigerant (max. 50 % refrigerant fraction)	
Delivery rate	5200 l/h \pm 10 % at 0.2 bar discharge pressure	
Water circuit operating pressure	max. 2 bar	
Weight (without bracket, clamp and refrigerant)	2.14 kg	
Rated voltage	24 volt	
Operating range	20 – 28 volt	
Power consumption at 5200 l/h and 0.2 bar discharge pressure	104 watt \pm 10 %	
Interference suppression class	3 according to DIN 57879 / Part 1 VDE 0879	
Protection	IP 54A according to DIN 40 050 Sheet 1	
Electrical fusing for third party control	15 A	
Temperature conditions	Heating medium	-40 °C to + 90 °C [short-term (15 min.) +115 °C]
	Ambient, operation	-40 °C to 90 °C [short-term (15 min.) +115 °C]
Dry running	No	
Blocking	Within a period of max. 6 seconds the motor is undamaged.	
Shaft - impeller connection	Mechanical seal	

Pumping and pressure loss characteristic curves

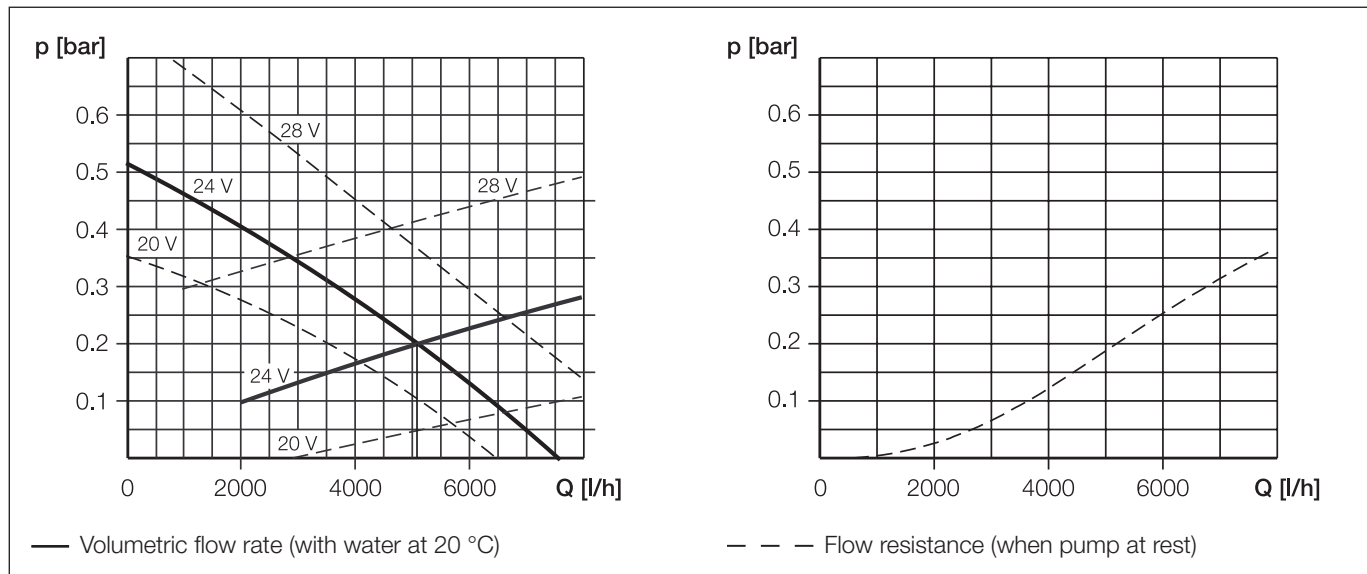

Sketch 4

Please note!

- If no limit values are given, the technical data listed is with the usual heater tolerances of \pm 10 % at nominal voltage, 20 °C ambient temperature and Esslingen reference altitude.
- The FLOWTRONIC 5000 water pump is installed in compact design heaters.
- If water pumps are ordered separately, please refer to the documentation supplied with them for the relevant technical data, installation positions, etc.



Important!

Safety instructions for technical data!

Failure to comply with the technical data can result in malfunctions.



4 Troubleshooting

What to check first in case of faults

- Faulty wiring (short circuits, interruption).
- Visual inspection for
 - corroded contacts
 - defective fuses
 - damaged electrical leads, connections and terminals
 - damaged exhaust and combustion air circuit.
- Battery voltage when heater started <19 Volt (measure voltage at control box).
- Check fuel supply.
- On changeover to winter service: Is summer diesel still in the line?
- Delayed start -> nozzle block heating switched on for 60 seconds.
- If there is a lack of coolant or the water pump's impeller is blocked, the Hydronic is automatically switched off soon after starting.

Locking the control box

The control box is locked if the following faults occur:

- Overheating
If the heater overheats 3x in succession – fault code 012, is displayed as AF 015 -> the control box is locked.
- Flame in after-run
If the fault "flame in after-run" is signalled 3x in succession – fault code 058, is displayed as AF 016 -> the control box is locked.
- Too many attempted starts
If the heater carries out ten failed start attempts in succession – fault code 052, is displayed as AF 050 -> the control box is locked.

Cancelling the control box lock

Cancellation of the control box lock is described on pages 15 to 20.

Cancelling control box lock without diagnostic equipment

If the heater is switched on, apply plus at 18-pin cable harness connector, pin 13, cable 1² ge/rt (water pump third party control) for approx. 3 sec. -> the control box is unlocked.

Additional options for locked control box from No. 25 1818 53 00 00

Apply plus at 18-pin cable harness connector, pin 9, cable 1² bl/sw for approx. 3 sec. -> the control box is unlocked.

4 Troubleshooting

Fault diagnosis – flashing code (LED with series resistor)

The electronic control box can store up to 5 faults. The defective component and type of fault are output by the control box as a flashing code and are displayed by an LED with series resistor (approx. 1 kΩ / 1W). The LED with series resistor is connected to the 8-pin connector of the heater cable harness (chamber 2, cable 1² bl/ws and chamber 5, cable 1² ge). The flashing codes of the defective components and the corresponding fault codes are described on page 12. Possible causes and remedial action are explained in the fault code tables (pages 21 – 24).

LED and series resistor

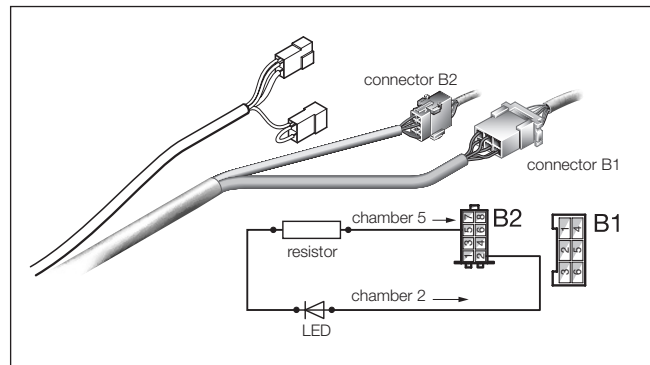

Sketch 5

Flashing code

	400 ms pause at the start of the flashing code	8 sec.	16 sec.
Operation without faults	[Solid bar]		
Flame detection photocell, Fault code 16, 51, 58	[Short pulse]	[Short pulse]	
Safety time exceeded, Fault code 50, 52	[Short pulse]	[Short pulse]	[Short pulse]
Flame cutout, Fault code 54	[Short pulse]		
Overheating, Fault code 12, 15	[Short pulse]	[Short pulse]	[Short pulse]
Burner engine, Fault code 32, 33	[Short pulse]	[Short pulse]	
Undervoltage cut-off, Fault code 11	[Short pulse]	[Short pulse]	
Overvoltage cut-off, Fault code 10	[Short pulse]	[Short pulse]	[Short pulse]
Temperature sensor, Fault code 14, 60, 61, 71, 72	[Short pulse]	[Short pulse]	[Short pulse]
Connection error, Fault code 20, 21, 25, 37 – 39, 44 – 49, 80 – 83	[Short pulse]	[Short pulse]	[Short pulse]
Control box, Fault code 90 – 97	[Short pulse]	[Short pulse]	[Short pulse]

Short pulse – flash duration:	0.4 sec.
Long pulse – flash duration:	2.0 sec.
Pause between the pulses:	0.4 sec.
Period of a flashing sequence:	8.0 sec.

Sketch 6



4 Troubleshooting

Overview of the individual test equipment and control units

The electronic control box can store up to 5 errors, which can be read out and displayed. The following test equipment can be used to query the fault memory in the control box and if necessary to delete the control box locking:

Test equipment	Order No.:
• Diagnostic unit	22 1529 89 00 00
additionally required:	
Adaptor cable	22 1000 31 66 00
• EDiTH customer service program	
– Basic adapter with software	22 1532 89 00 00
additionally required:	
Hydronic L extension	22 1539 89 00 00
– ISO adapter	22 1524 89 00 00
additionally required:	
Adaptor cable	22 1000 31 66 00
• Burner tester	22 1527 89 00 00

If a diagnostics cable is connected, the following control units can also be used to query the fault memory in the control box and if necessary to delete the control box locking:

Control units	Order No.:
• Module timer	22 1000 30 34 00
• TP5 radio remote control	22 1000 32 01 00
• EasyStart T	22 1000 32 88 00
• EasyStart R+	22 1000 32 80 00

Please note!

If the fault memory cannot be read out, check the diagnostics cable for correct laying and possible damage.

External diagnostic system

With an external, vehicle-specific diagnostic system
-> contact the vehicle manufacturer.

4 Troubleshooting

Diagnostic unit

(Order No.: 22 1529 89 00 00)

To connect the diagnostic unit, an additional adapter cable is required (Order No.: 22 1000 31 66 00).

The current fault is displayed as "AF" and a 2-digit number and is always written in the memory location F1. Preceding faults are moved to the memory locations F2 – F5, if necessary the contents of memory location F5 is overwritten.

Please note!

- Not only the defective component, but also a defective current circuit results in a fault being displayed.
- Fault code, fault description, cause / remedial action are described on Pages 21 – 24.

Connect diagnostic unit

- Disconnect the 8-pin connector of the heater's cable harness and connect the adapter cable.
- Connect the diagnostic unit to the adapter cable.
Display is as follows:



Query fault memory

- Use the [D] key to switch on the heater.
Display is as follows:

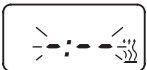

- After 8 sec the following is displayed:
Display is as follows:



Heater has no malfunction

or

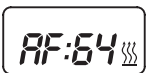

e.g. current error / fault code 64

or



Fault diagnosis not possible

Possible causes:

- Adapter cable is not properly connected.
- Control box is defective or is not capable of diagnosing (not a universal control box).

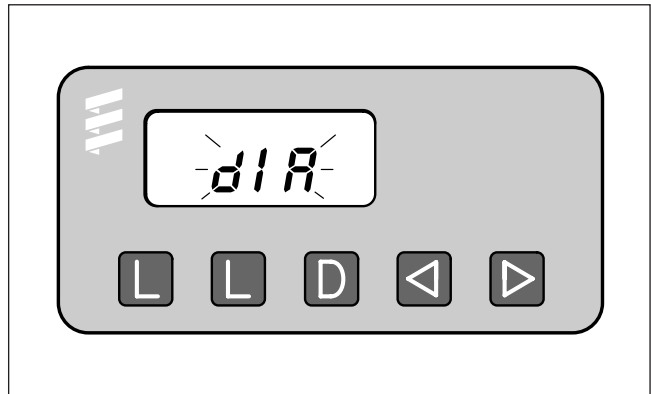

Sketch 7

- [L] – Delete fault memory
- [L] – Delete fault memory
- [D] – Switch heater on / off, request diagnosis
- [◀] – Return, F5 – F1
- [▶] – Flow, F1 – F5, current fault (AF)

Display of the fault memory F1 – F5 or F5 – F1

- Press the [◀] or [▶] button again, or press several times, to display the fault memory.
Display is as follows:

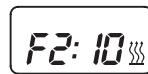

e.g. fault memory 2 / fault code 10

Please note!

Only the fault memory locations with an error assigned to them are displayed.

Delete fault memory

- Press both [L] buttons simultaneously until the following appears in the display:
Display is as follows:



- If the fault memory has been deleted the most recent current fault is displayed. The current fault is not reset to 00 until the heater is restarted – provided there is no new, more recent fault.

Display is as follows:



Heater has no faults

4 Troubleshooting

Cancel the control box lock

- Delete the fault memory as described and switch off the heater using the **[D]** key.
- The control box lock is cancelled and the diagnosis closed.
Display is as follows:

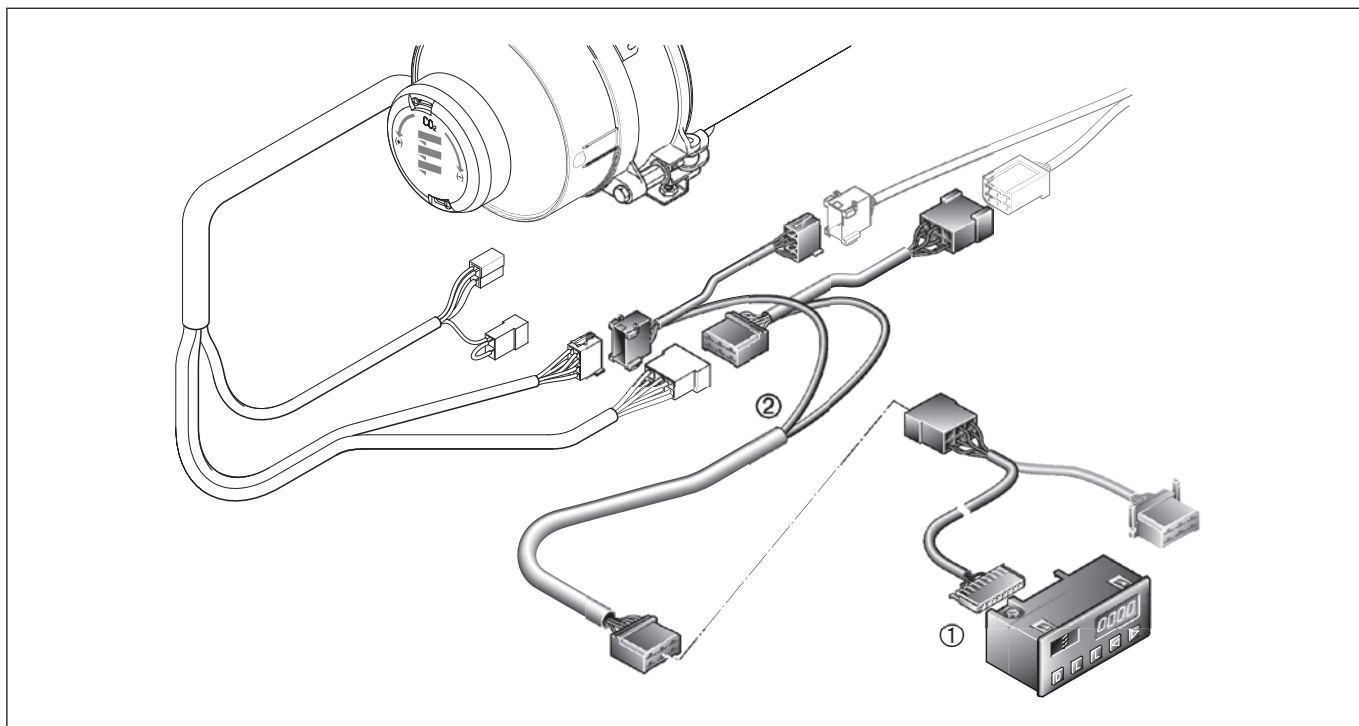

Sketch 8

- ① Diagnostic unit with connection cable
- ② Adaptor cable

4 Troubleshooting

EDiTH customer service program with ISO adapter

(Order No.: 22 1524 89 00 00)

An additional adapter cable is required to connect the ISO adapter (Order No.: 22 1000 31 66 00).

Please note!

- It is very important to always install in the given order.
- Not only the defective component, but also a defective current circuit results in a fault being displayed.
- Fault code, fault description, cause / remedial action are described on Pages 21 – 24.
- The EDiTH customer service program software is not included in the scope of supply, it must be downloaded from the service portal.
- Faults 1 – 5 only are displayed in heaters up to serial No. 12 000.
In addition to faults 1 –5, measured values are also displayed in heaters from serial No. 12 001.

Connect ISO adapter

- Disconnect the heater's cable harness.
- Connect the adapter cable to the cable harness – as shown in the sketch.
- Connect the adapter cable to the ISO adapter.
- Connect the SUB-D connection cable with the PC and the ISO adapter.

Installing software on the PC

- Double-click "setup.exe" file to start and follow the SETUP program instructions.

Query / delete fault memory F1 – F5 or cancel the control box lock

- Start the software at the PC:
 - on the desktop → double-click the "EDiTH" icon
 - Select heater type
 - Press the "GO" button.
- Delete fault memory or cancel the control box lock:
 - Press the "Delete fault memory" button
 - the stored faults F1 – F5 are deleted and the control box is unlocked.

Quit diagnosis

- Press the "STOP" button → fault memory query is ended.

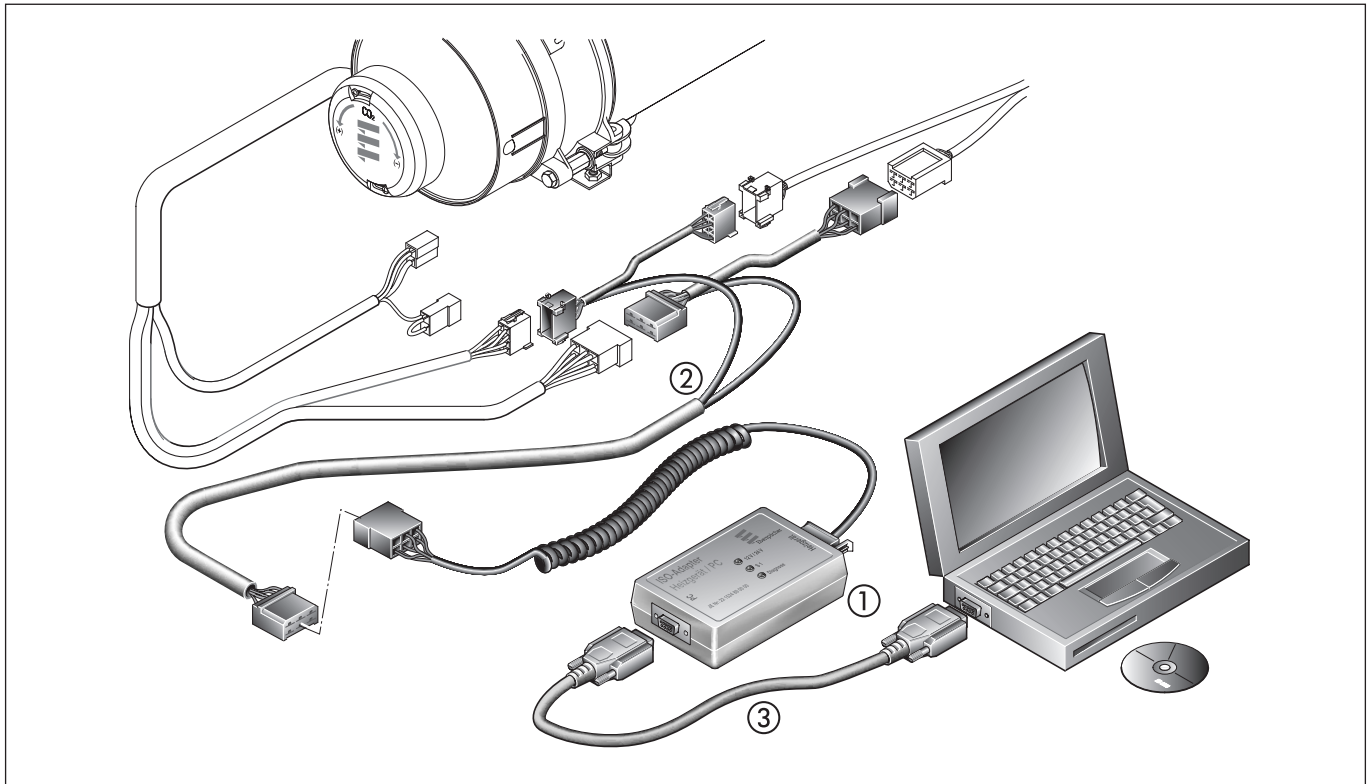

Sketch 9

- ① ISO adapter
- ② Adaptor cable
- ③ SUB-D connection cable



4 Troubleshooting

EDiTH customer service program with basic adapter

EDiTH basic adapter
(Order No.: 22 1532 89 00 00)

An additional extension is required to check the control box
(Order No.: 22 1539 89 00 00).

Please note!

- It is important to always follow the precise connection order as given below!
- The flame failure safeguard integrated in the control box can only be tested properly if the corresponding mating connector (a) is connected.
- Only push or pull on the connectors, not on the cables!
- Only use the network cable and RS232 cable with snap ferrites included in the scope of supply. Use original accessories with snap ferrites only to connect the test equipment.
- Not only the defective component, but also a defective current circuit results in a fault being displayed.
- Fault code, fault description, cause / remedial action are described on Pages 21 – 24.

Important! Magnetic field!

During the test operation a magnetic field develops at the adapter. Therefore, do not place any objects such as data media, credit cards, etc. on the adapter or in its immediate vicinity.

Connect basic adapter

- Start computer and wait until the system has successfully booted.
- Start PC software.
- Insert the unit connector of the mains cable in the basic adapter and connect the mains connection to the mains.
- Connect the SUB-D connection cable with the PC and basic adapter.

Connect extension and test control box

- Connect the extension to the basic adapter.
 - Connect extension and basic adapter to control box.
 - Switch on basic adapter at mains switch.
 - Select the control box version and operating voltage (12 V / 24 V) in the PC software.
 - Start the control box test with the PC software.
- A more detailed description of how to operate the basic adapter is given in the EDiTH online help.

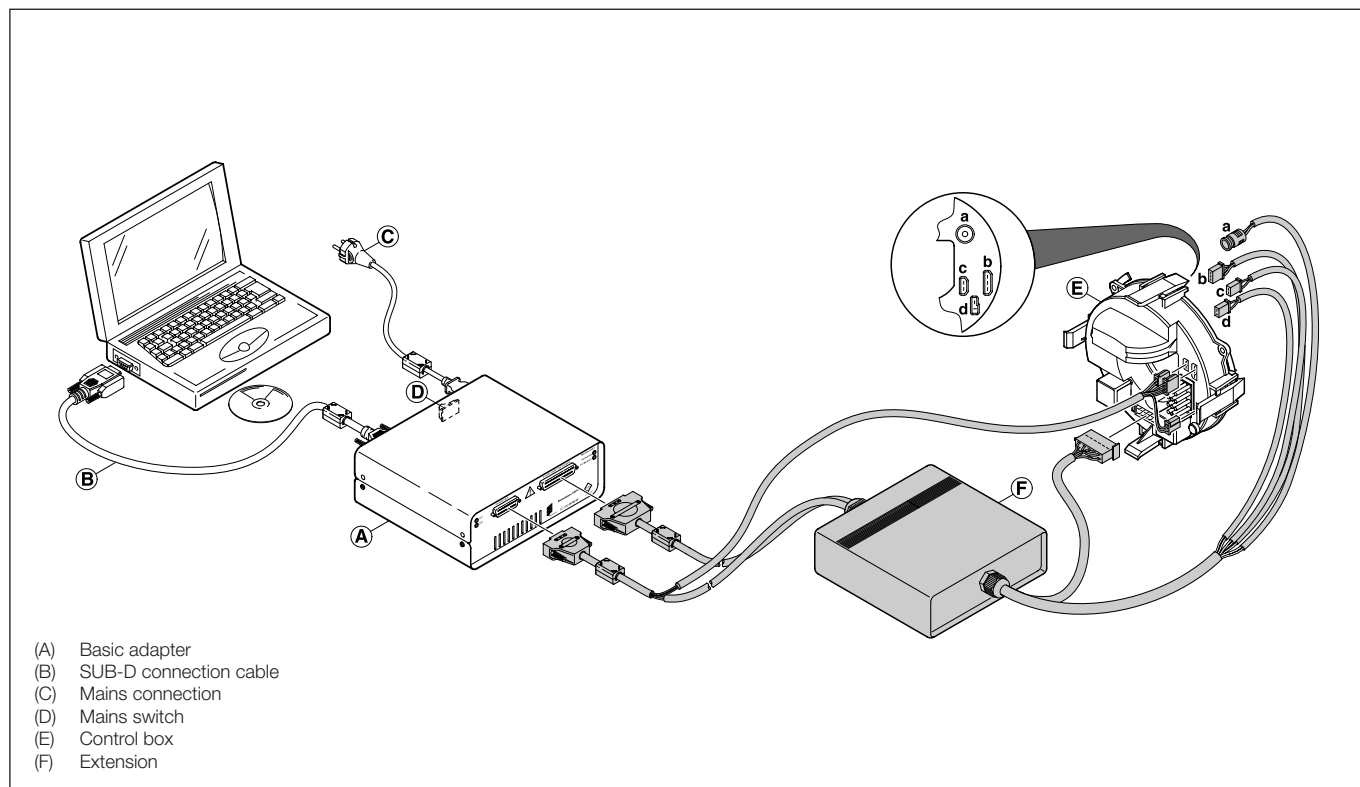

Sketch 10

4 Troubleshooting

Module timer

(Order No.: 22 1000 30 34 00)

The current fault is displayed as "AF" and is always written in the memory location F1.

Preceding faults are moved to the memory locations F2 – F5, if necessary the contents of memory location F5 is overwritten.

Please note!

- Not only the defective component, but also a defective current circuit results in a fault being displayed.
- Fault code, fault description, cause / remedial action are described on Pages 21 – 24.

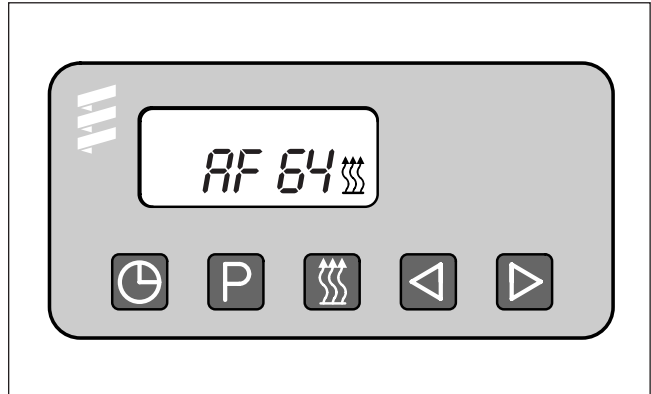

Sketch 11

- 🕒 – Time
- P – Preset
- 🔥 – Heat
- ⏪ – Return
- ⏩ – Flow

Query fault memory F1 – F5

Condition:

The heater is switched off.

- Press 🔥 key → the heater is switched on.
- Press 🕒 key and keep pressed, then press P key within 2 seconds.
Display is as follows:
AF = current fault
3 digit number = fault code
🔥 flashes.
- Press the ⏩ key or press it several times,
Fault memory F1 – F5 are displayed.

Cancel the control box lock and simultaneously delete the fault memory

Condition:

An electrical connection exists from terminal 15 (ignition) to the module timer, 12-pin connector, chamber 10.

- Press 🔥 key
Display is as follows:
the current fault, e.g. F15.
- Press 🕒 key, keep pressed and press P key within 2 seconds.

The module timer is now in the "Query fault memory" program.

- Switch off ignition (terminal 15).
- Simultaneously press button 🕒 and button P, in addition, switch on the ignition (terminal 15) and wait until the following appears in the display.

After ignition "ON" the following appears in the display:

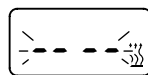

Display flashes,
Heater symbol does not flash

- Switch the heater off and on → the control box is unlocked, the heater restarts.

After switching the heater off and on and renewed query of the fault memory, the following appears in the display:



Display flashes,
Heater symbol does not flash

4 Troubleshooting

TP5 radio remote control

(Order No.: 22 1000 32 01 00)



If faults occur while the heater is running, they are displayed with "Err" after the mobile unit is activated.

The current fault "F0" is displayed. The stored faults "F1" to "F5" can be queried.

Please note!

- In order to carry out the diagnosis, the diagnostics cable (bl/ws) must be connected to the stationary unit and the heater cable harness. To this end, please refer to and follow the circuit diagram for the TP5 radio remote control and the heater.
- If the diagnostics cable (bl/ws) is not connected, the "Diagnosis" menu is blocked.
- Not only the defective component, but also a defective current circuit results in a fault being displayed.
- Fault code, fault description, cause / remedial action are described on Pages 21 – 24.

Enquire / delete fault memory

Use the  key to activate the mobile unit.
Switch on the heater with the  key.
Press the  key twice to open the Time setting menu – the time flashes in the display.

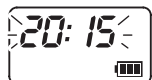

Press the  key for approx. 2 sec – until the following appears in the display:





Further key sequence:

- Press  key.
- Press  key.
- Press  key twice.
- Press  key.

Display





Heater with fault or heater without fault:

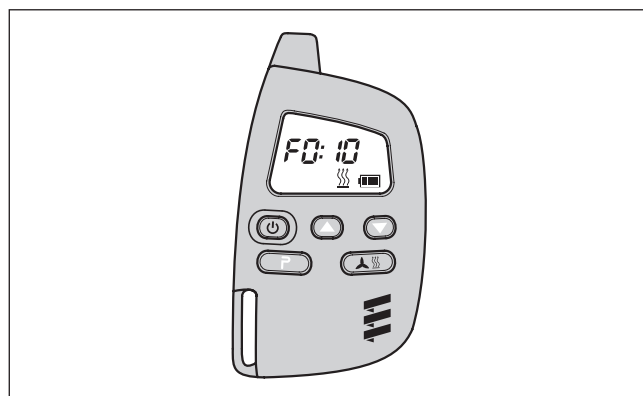

Use the  and  keys to open the fault memory locations 1 to 5.





Sketch 12

-  Button to activate / deactivate the mobile unit
-  Next control key
-  Back control key
-  Button for activating the possible settings
-  Button for switching heat / ventilate ON / OFF; Activate / deactivate preselected time and open fault memory.

Delete fault memory / Cancelling the control box lock

Use the  key to delete the fault memory.



To confirm, press the  key for approx. 2 sec until  lights up in the display – fault memory is deleted.



Please note!

If the fault memory is to be deleted later or the control unit lock cancelled later, the whole procedure must be repeated.

4 Troubleshooting

EasyStart R+ radio remote control

(Order No.: 22 1000 32 80 00)

EasyStart T timer

(Order No.: 22 1000 32 88 00)

If faults occur while the heater is running, they are displayed with "Err" after the mobile unit or timer is activated.

The current fault is displayed. The stored faults "F1" to "F5" can be queried.

Please note!

- Prerequisite for carrying out the diagnosis is that the diagnostic cable bl/ws is connected. To this end, please refer to and follow the circuit diagram for the radio remote control and / or the timer.
- If the diagnostics cable is not connected the "Diagnosis" menu is blocked.
- Not only the defective component, but also a defective current circuit results in a fault being displayed.
- Fault code, fault description, cause / remedial action are described on Pages 21 – 24.

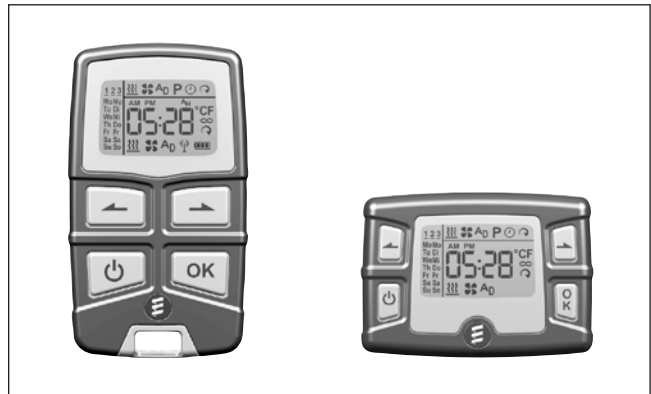

Sketch 13

- Back control key
- Next control key
- ON / OFF activation key mobile unit / timer
- OK key (symbol selection / confirm input)

Enquire / delete fault memory

Activate mobile part / timer
(see EasyStart R+ / EasyStart T operating instructions)

Confirm symbol with .

Heater is switched on.

Confirm operating time with .

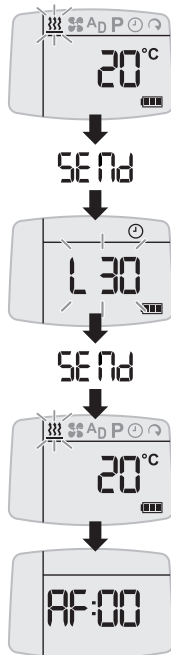

Briefly press and simultaneously.

The following actions are possible

- Call up fault memory.
Open the fault memory locations F1 – F5 with or .
 - Call up fault memory again.
Briefly press and simultaneously.
 - Delete fault memory (display dEL)
Press .
- Press again.

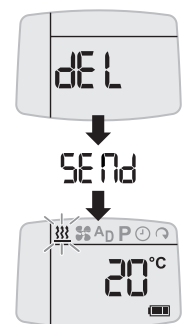



The diagnosis is completed.

Switch off heater.



4 Troubleshooting

Fault code table

Fault code display	Fault description	Cause • Remedial action
000	No fault	--
010	Overvoltage cut-off	Overvoltage (> 30 volt) applied to control box for at least 20 seconds without interruption – heater not working. • Disconnect 18-pin connector at control box, start the vehicle's engine. Measure the voltage between PIN 15 (cable 2.5 ² rt) and PIN 16 (cable 2.5 ² br), if voltage > 30 volt → check generator controller.
011	Undervoltage cut-off	Under voltage (< 19 volt) applied to control box for at least 20 seconds without interruption – heater not working. • Disconnect 18-pin connector at control box, start the vehicle's engine. Measure the voltage between PIN 15 (cable 2.5 ² rt) and PIN 16 (cable 2.5 ² br). The measured value and the voltage at the battery should be the same. In case of a voltage drop, check the fuses, the supply cables, the negative connections and the positive support point on the battery for correct contact.
012	Overheating	Temperature at overheating sensor >130 °C • Check water circuit: – Check all hose connections for leaks – Vent water circuit – Check valves in water circuit, replace if necessary – Temperature difference between water inlet and water outlet must be <10 K, if not → check minimum flow rate of the heating medium, for values see technical data. • Check water pump, replace if necessary. • Check overheating sensor, replace if necessary, see diagram on page 36.
014	Difference between the overheating and temperature sensor is too large	Difference between measured values of the temperature sensor and overheating sensor impermissibly high for a lengthy time. • Check installation of both sensors, tighten sensor if necessary, tightening torque for both sensors 2.5 Nm + 0.5 Nm. • Check temperature sensor and overheating sensor, see diagram on pages 35 and 36. • Check minimum flow rate of the heating medium, see technical data for values.
015	Operating lock-out – Control box is locked	Fault code 012 "Overheating" three times in succession → fault code 015 is displayed. Unlock the control box by deleting the fault memory, see pages 15 to 20. • For remedial action see fault code 012.
016	Operating lock-out – control box is locked	Fault code 058 "flame in after-run" three times in succession → fault code 016 is displayed. Unlock the control box by deleting the fault memory, see pages 15 to 20. • For remedial action see fault code 058.
020	Ignition unit interruption  Danger! High voltage!	Control lead from ignition unit to control box is interrupted or short-circuited. • Check cable loom from ignition unit to control box, if necessary remove interruption or short circuit. • Check function of ignition unit only using burner tester, replace ignition unit if necessary. • If faults are not corrected by the remedial action listed above → replace control box.
021	Ignition unit earth short  Danger! High voltage!	Earth short in control lead from ignition unit to control box. • Check cable loom from ignition unit to the control box, if necessary remove earth short. • Check function of the ignition unit only using the burner tester, replace ignition unit if necessary. • If faults are not corrected by the remedial action listed above → replace control box.

4 Troubleshooting

Fault code table

Fault code display	Fault description	Cause • Remedial action
025	Diagnosis output short circuit	Cable 1 ² bl/ws from 18-pin control box connector, chamber 12 to 8-pin cable harness connector, chamber 2 has short circuit with + U _B . • Check cable and connections, if necessary remove short circuit.
032	Burner motor does not rotate at start	Impeller chafes or is blocked. Burner motor is defective.
033	Burner motor does not rotate during operation  Apply max. 12 volt at burner motor	Generator voltage is too low. • Check impeller for free running. • Check cables and connections to burner motor. • Check function of installed burner motor only using burner tester, replace burner motor if necessary. • If faults are not corrected by the remedial action listed above → replace control box. Fuel pump is blocked. • Check fuel pump for free running, replace burner if necessary.
037	Water pump fault	Check first: • Water pump Bus 2000 / FLOWTRONIC 6000 S is installed? • "Diagnosis" cable loom from the Bus 2000 water pump is connected? • Voltage applied to the Bus 2000 water pump? If yes – Disconnect plug-in connector from "Diagnose" cable loom. Heater start – If fault code 037 is no longer displayed, then check Bus 2000 water pump for dry running or blocking. – If fault code 037 is still displayed, then use remedial action as described for the water pump (standard design). • Water pump (standard design / FLOWTRONIC 5000 / 5000 S) is installed? If yes – Disconnect plug-in connector from "water pump" cable loom, apply voltage to 2-pin connector of the "water pump" connector and check function. If the water pump is functioning ok, then check fuse (15 A), cable loom and connections of the water pump → if fault code 037 still displayed, then replace the control box.
039	Vehicle blower control short circuit	Cable 1 ² sw from 18-pin control box connector, chamber 6 to 8-pin cable harness connector, chamber 7, on to blower relay is short-circuited. • Check cable and connections, if necessary remove short circuit. • Check installation of the relay. • Replace relay. • If faults are not corrected by the remedial action listed above, then replace control box.
044	Water pump Relay coil interruption	• Check installation of the relay at the control box. • Replace relay.
045	Water pump Relay coil short circuit	• If faults are not corrected by the remedial action listed above, then replace control box.
046	Solenoid valve interruption	"Solenoid valve" cable loom from control box (connector position "D") to solenoid valve is interrupted or has earth short. • Check cables and connections from solenoid valve, remove earth short if necessary. • Replace solenoid valve coil. • If faults are not corrected by the remedial action listed above, then replace control box.
047	Solenoid valve short circuit	"Solenoid valve" cable loom from control box (connector position "D") to solenoid valve has earth short. • Check cables and connections from solenoid valve, remove earth short if necessary. • Replace solenoid valve coil. • If faults are not corrected by the remedial action listed above, then replace control box.



4 Troubleshooting

Fault code table

Fault code display	Fault description	Cause • Remedial action
048	Nozzle block heating Relay coil interruption	<ul style="list-style-type: none"> • Check installation of the relay at the control box. • Replace relay.
049	Nozzle block heating Relay coil short circuit	
050	Operating lock-out Control box is locked	Control box locked by 10 start attempts without flame detection. Unlock the control box by deleting the fault memory, see pages 15 to 20. <ul style="list-style-type: none"> • For remedial action see fault code 052.
051	Flame detection photocell signals "Flame before fuel"	<ul style="list-style-type: none"> • Replace burner.
052	Safety time exceeded, no start  Danger! High voltage! Note when checking the ignition unit	No flame detected within the ignition phase. <ul style="list-style-type: none"> • Check combustion air inlet and exhaust system. • Check fuel supply (flow and return). • Check flame tube for correct installation in heat exchanger. • Check function of ignition unit only using burner tester, replace ignition unit if necessary. • Check distance between ignition electrodes, if necessary renew ignition electrodes. • Check electric cables and connections. • Check flame detection photocell for dirt, clean if necessary. • Replace fuel nozzle. • If faults are not corrected by the remedial action listed above, then replace control box.
054	Flame cutout during operation	Heater has ignited, the flame is detected and signals flame cutout twice within an operating time of 60 minutes. <ul style="list-style-type: none"> • Check fuel supply (flow and return). • Carry out CO₂ measurement. • Replace fuel nozzle. • If faults are not corrected by the remedial action listed above, then replace control box.
058	Flame does not extinguish during after-run	Flame detection photocell signals that flame has not extinguished 30 seconds after after-run "ON". <ul style="list-style-type: none"> • Check heat exchanger, clean if necessary, then carry out CO₂ measurement. • Test the solenoid valve using the burner tester, replace if necessary. • If fuel continues to be pumped during after-run → replace fuel pump. • If faults are not corrected by the remedial action listed above, then replace control box.
060	Temperature sensor interruption	Temperature value outside operating range. <ul style="list-style-type: none"> • Check plug-in connection with temperature sensor and cable to the control box. • Check temperature sensor, see diagram on page 35. • If faults are not corrected by the remedial action listed above, then replace control box.
061	Short circuit in temperature sensor	<ul style="list-style-type: none"> • If faults are not corrected by the remedial action listed above, then replace control box.
071	Overheating sensor interruption	Temperature value outside operating range. <ul style="list-style-type: none"> • Check plug-in connection with overheating sensor and cable to the control box. • Check overheating sensor, see diagram on page 36. • If faults are not corrected by the remedial action listed above, then replace control box.
072	Short circuit in overheating sensor	<ul style="list-style-type: none"> • If faults are not corrected by the remedial action listed above, then replace control box.
081	Combustion indicator light short-circuit	Cable 1 ² ge/ws from 18-pin control box connector, chamber 8 to 8-pin cable harness connector, chamber 3, on up to combustion indicator light is short-circuited. <ul style="list-style-type: none"> • Check cable and connections, if necessary remove short circuit. • Check combustion indicator light, replace if necessary.

4 Troubleshooting

Fault code table

Fault code display	Fault description	Cause • Remedial action
083	Fault indicator light short circuit	Cable 1 ² gr from 18-pin control box connector, chamber 5 to 8-pin cable harness connector, chamber 6, on to fault indicator light is short-circuited. <ul style="list-style-type: none">• Check cable and connections, if necessary remove short circuit.• Check fault indicator light, replace if necessary.
090	Control box defective	<ul style="list-style-type: none">• Replace control box.
091	External interference voltages	Possible causes: <ul style="list-style-type: none">• Distance between ignition electrodes not ok → check distance between ignition electrodes, if necessary renew ignition electrodes.• Interference voltages from charger or other sources of interference → Remove interference voltages.• If faults are not corrected by the remedial action listed above, then replace control box.
092 093 094 097	Control box defective	<ul style="list-style-type: none">• Replace control box.

5 Repair instructions

Repair instructions

The permitted repair work on the heater is described in the "Repair Instructions" chapter. If extensive repairs are necessary, it makes sense to dismantle the heater.

The heater is assembled in the reverse order, if applicable not additional instructions.

Please note!

After completing all the work on the heater, you must carry out a functional check.

Always observe the following safety instructions before working on the heater



Danger!

- Always switch off the heater beforehand and leave it to cool.
- Disconnect the battery.
- Relieve the overpressure in the cooling water circuit by opening the radiator screw cap.
- Do not switch on the heater if burner is dismantled.
- Before removing the ignition unit, disconnect plug-in connections in cable harness.
- The heater must not be operated in closed rooms such as garages or workshops.

Exception:

Exhaust suction available directly at the entry to the exhaust pipe.



Important!

- The seals of dismantled components must be renewed.
- During repair work, check all components for damage and if necessary replace.
- Check connector contacts, plug-in connections and cables for corrosion and damage and if necessary repair.
- Only ever use Eberspächer spare parts if replacements are necessary.
- After working on the cooling water circuit the level of the cooling water must be checked and if necessary the refrigerant must be topped up according to the vehicle manufacturer's instructions.
The cooling water circuit must then be vented.
- Operation or the after running of the heater may only be stopped in an emergency (see "EMERGENCY OFF" Page 8) by interrupting the battery current (risk of heater overheating).

AMP release tool

The AMP release tool is used to unclip push-on sleeves from a connector housing.

This release tool can be ordered directly from Eberspächer GmbH & Co. KG.

- For Micro Timer Order No. 206 00 205
- For Junior Power Timer Order No. 206 00 215



Sketch 14
AMP release tool

5 Repair instructions

Assembly drawing

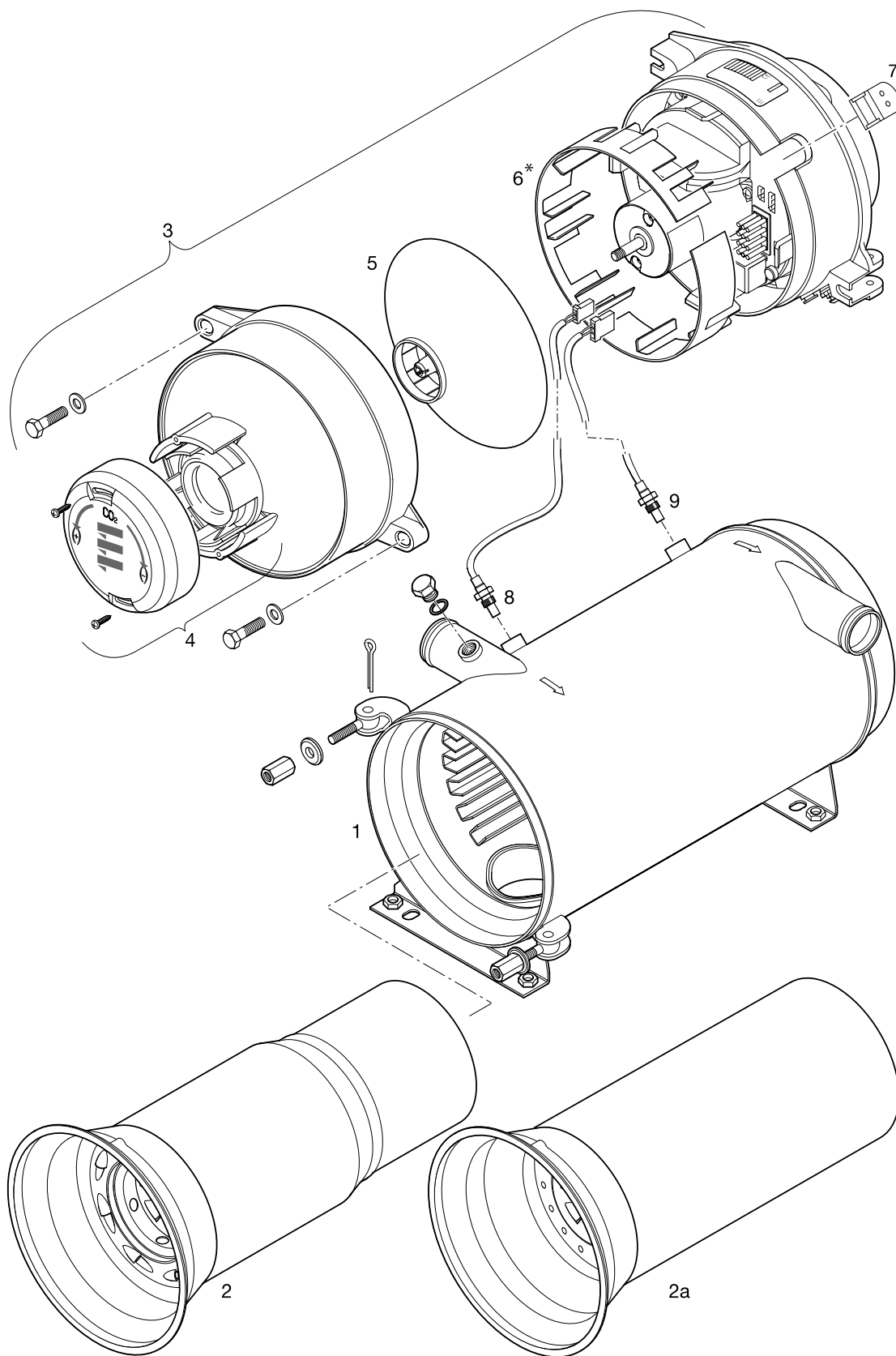

5 Repair instructions

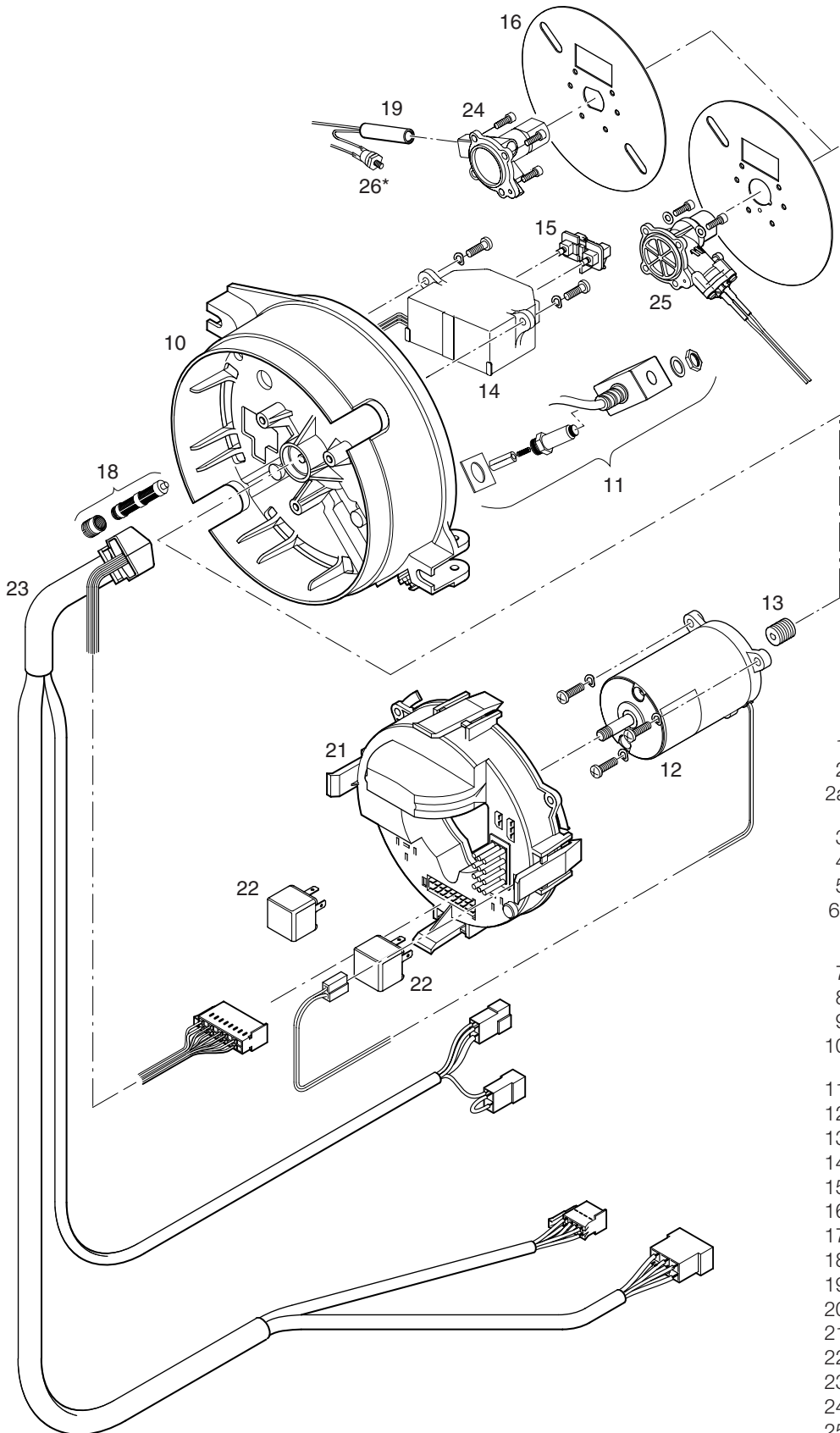

Component parts

- 1 Heat exchanger
- 2 Flame tube, complete
- 2a Flame tube, complete
(unit version 25 1817 and 25 2165)
- 3 Burner
- 4 Hood
- 5 Impeller
- 6* Controlling system
(unit version 25 1817 and 25 2165;
however, not installed in all heaters)
- 7 Grommet
- 8 Temperature sensor
- 9 Overheating sensor
- 10 Fuel pump
(integrated in burner housing)
- 11 Solenoid valve
- 12 Electric motor, 24 volt
- 13 Coupling
- 14 Ignition unit, 24 volt
- 15 Ignition electrode
- 16 Baffle plate
- 17 Fuel nozzle
- 18 Screen insert/strainer
- 19 Heating cartridge
- 20 KL fuse
- 21 Control box, 24 volt
- 22 Relay
- 23 Wiring harness
- 24 Nozzle block made of brass
- 25 Nozzle block made of plastic with
integrated heating element
- 26* Temperature switch for nozzle
block made of brass
(unit version 25 1817 and 25 2165)

Sketch 16-

5 Repair instructions

Removing the hood (see Sketch 17)

- Loosen both of the hood's retaining screws.
- Remove hood.



Risk of injuries!

- The impeller has sharp edges.
 - Avoid touching the impeller or if necessary wear safety gloves.

- ① Retaining screw

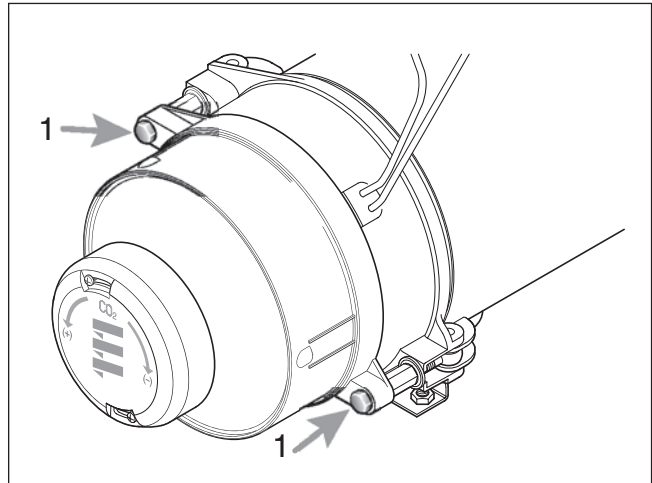

Sketch 17

Dismantling burner (see Figure 1)

- Remove hood.
- Disconnect "temperature sensor" cable loom and "overheating sensor" cable loom at control box.
- Remove grommet from burner housing.

Please note!

The fuel lines should remain connected, if necessary extend the fuel lines.

- ① Burner
② Heat exchanger
③ Grommet
④ "Temperature sensor" cable loom and "overheating sensor" cable loom

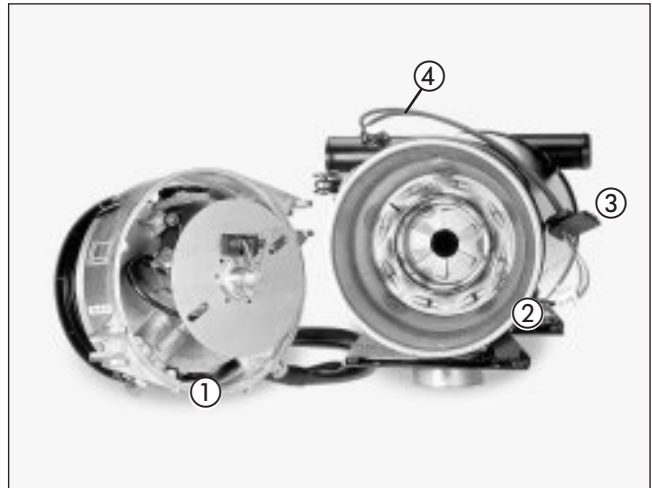

Figure 1

Dismantle control box (see Figure 2)

- Remove hood.
- Dismantle the burner.
- Undo impeller in anti-clockwise direction, at the same time pressing against the motor shaft with a screwdriver.
- Disconnect all connectors at the front and rear of the control box.
- Unlock and remove control box with 4 clamps.

- ① Control box
② Clamps
③ Motor shaft (thread)

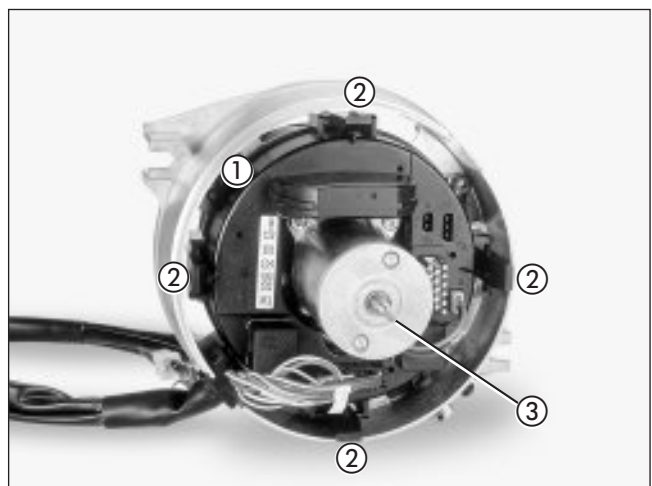

Figure 2

5 Repair instructions

Dismantling the burner motor (see Figure 3 and 4)

- Remove hood.
- Dismantle the burner.
- Undo impeller in anti-clockwise direction, at the same time pressing against the motor shaft with a screwdriver.
- If necessary, use the burner tester to test the burner motor (see below).
- Disconnect "burner motor" cable loom at control box, slot "B".
- Undo three retaining screws of burner motor.
- Remove burner motor.

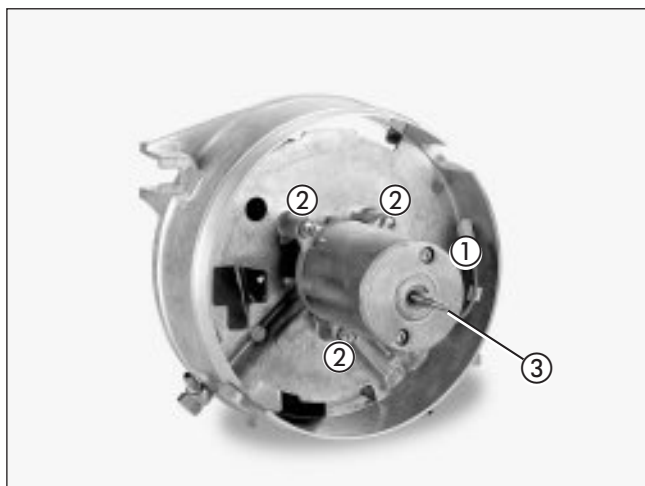

Figure 3

- ① Electric motor
- ② Retaining screws
- ③ Motor shaft (thread)

Please note!

When assembling, tighten the impeller with 1 Nm +0.5 Nm.

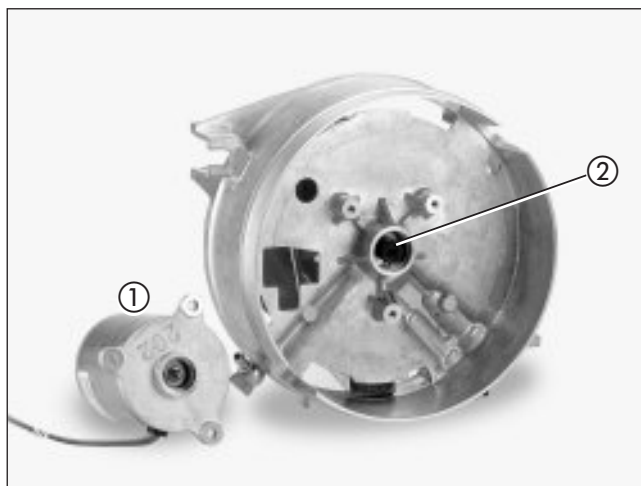

Figure 4

- ① Electric motor
- ② Coupling

Check function and speed of the burner motor using the burner tester (see Sketch 18)

- Disconnect all connectors from the control box.
- Connect burner tester.
- Make a mark on the impeller.
- Keep "Heating ON" pressed for 4 seconds → the heater starts, the electric motor must run for 180 seconds (after-run) →
 - if yes, measure speed using non-contact tachometer.
 - if no, replace the electric motor.

Speed of the electric motor

Hydronic 16	3800 ±350 rpm
Hydronic 24	4200 ±350 rpm
Hydronic 30	4800 ±350 rpm
Hydronic 35	5200 ±350 rpm



Risk of injuries!

- The impeller has sharp edges.
 - Avoid touching the impeller or if necessary wear safety gloves.

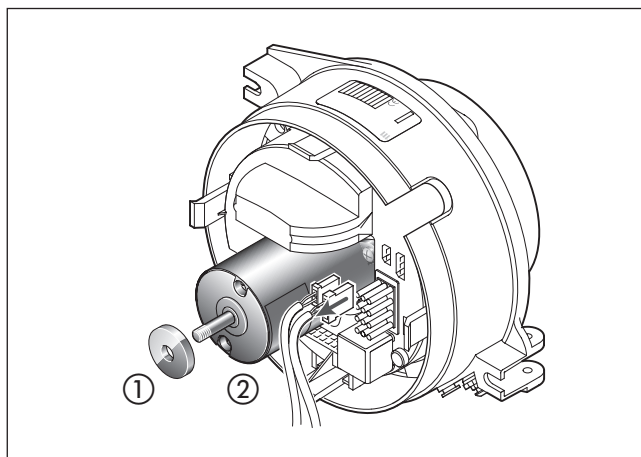

Sketch 18

- ① Impeller with mark

Please note!

Read and follow the burner tester operating instructions. Let the electric motor to run for 180 seconds.

5 Repair instructions

Dismantle ignition electrodes (see Figure 5 and Sketch 19)

- Remove hood.
- Dismantle the burner.
- Disconnect ignition electrodes from ignition unit.

Please note!

- If the Ignition spark generator, ignition electrodes or pump housing is replaced it is necessary to check the distance between the ignition electrodes with a check gauge. The check gauge is included with the spare parts.
- Place the check gauge on the fuel nozzle and push up to the limit stop. The electrode tips must lie against the square surfaces of the check gauge, if not → renew ignition electrodes.
- If the insulation body of the ignition electrodes is damaged → renew ignition electrodes.
- Do not touch the fuel nozzle opening when measuring the electrode spacing.
- The check gauge is solely for checking and not for setting the distance between the electrode tips.
- If the distance between the ignition electrodes differs from what it should be → renew ignition electrodes.
- Bending the ignition electrodes is **not** allowed.

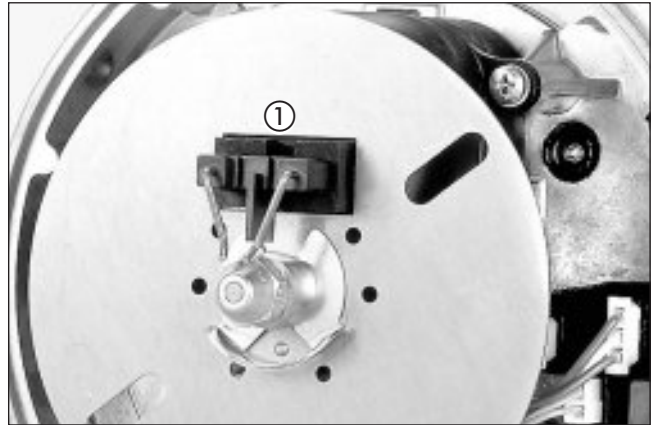
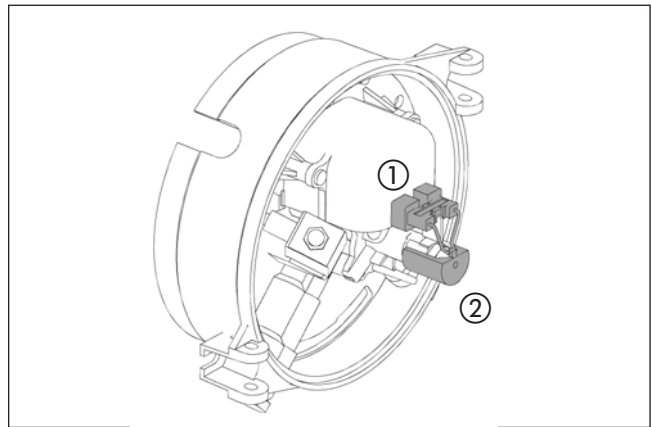

Figure 5

- ① Ignition electrodes



Sketch 19

- ① Ignition electrodes
② Check gauge

Dismantle fuel nozzle (see Figure 6)

- Remove hood.
- Dismantle the burner.
- Dismantle the ignition electrodes.
- Undo fuel nozzle from the nozzle block, press against the nozzle block with wrench.

Please note!

- When installing the fuel nozzle do not touch the nozzle opening.
- After installing the fuel nozzle, check the position of the ignition electrodes, renew if necessary.
- Tightening torque for fuel nozzle:
 - for nozzle block made of brass 16 +1 Nm.
 - for nozzle block made of plastic 2 +0.5 Nm.



Figure 6

- ① Fuel nozzle
② Ignition electrodes
③ Baffle plate
④ Flame detection photocell

5 Repair instructions

Dismantle ignition unit (see Figure 7 – 9)

- Remove hood.
- Dismantle the burner.
- Dismantle the ignition electrodes.
- Pull fuse clip (KL fuse) off nozzle block and remove baffle plate.
- If necessary, use the burner tester to test the ignition unit (see below).
- Disconnect ignition unit cable loom at control box, slot "E".
- Undo both retaining screws of ignition unit.
- Remove ignition unit.

Please note!

- When installing insert the ignition unit in the burner housing holders.
- Check distance between ignition electrodes, if necessary renew ignition electrodes.
- Lay the cable harnesses as shown in Figure 8 and 9.

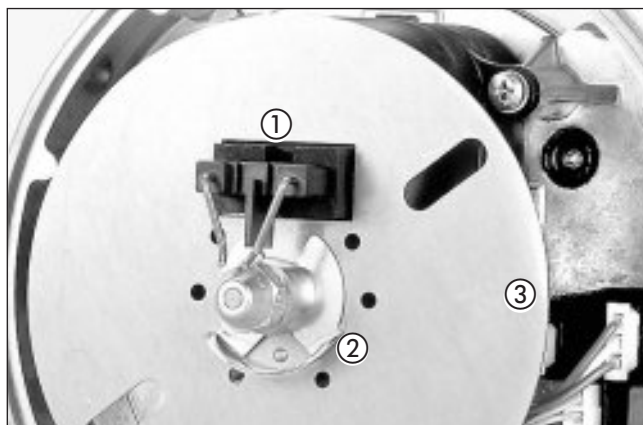

Figure 7

- ① Ignition electrodes
- ② Fuse clip (KL fuse)
- ③ Baffle plate

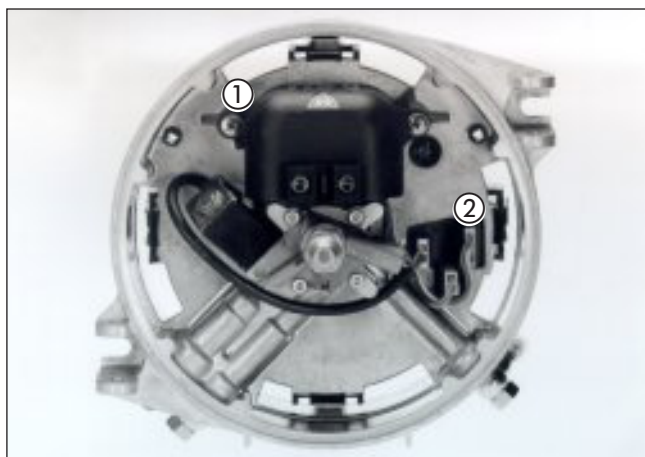

Figure 8

- ① Ignition unit
- ② Connection of the "ignition unit" cable loom at control box, slot "E"

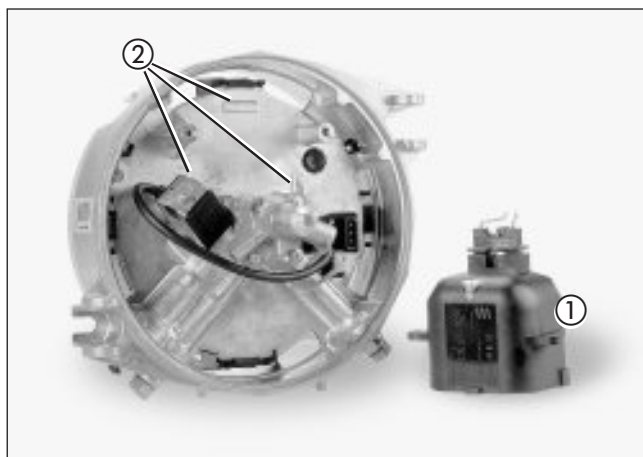

Figure 9

- ① Ignition unit
- ② Holders for the ignition unit

Testing the ignition unit using the burner tester



Danger!

- A spark gap with a voltage of approx. 20 000 volt forms between the electrodes.
 - Test the ignition unit only using the burner tester.
 - Do not test ignition unit without ignition electrodes.



High voltage!

Always note when testing the ignition unit!

Functional check

- Disconnect all connectors from the control box.
- Connect burner tester.
- Press "ZFG" button → a spark gap must form between the electrodes
 - if not, replace the ignition unit.

5 Repair instructions

Dismantling the solenoid valve (see Figure 10 and Sketch 20)

- Remove hood.
- Dismantle the burner.
- If necessary, use the burner tester to test the solenoid valve (see below).
- Disconnect "solenoid valve" cable loom at control box, slot "D".
- Loosen hexagon nuts from solenoid valve.
- Remove solenoid valve coil.
- Undo magnet.

Please note!

When installing lay the cable looms as shown in Figure 10.

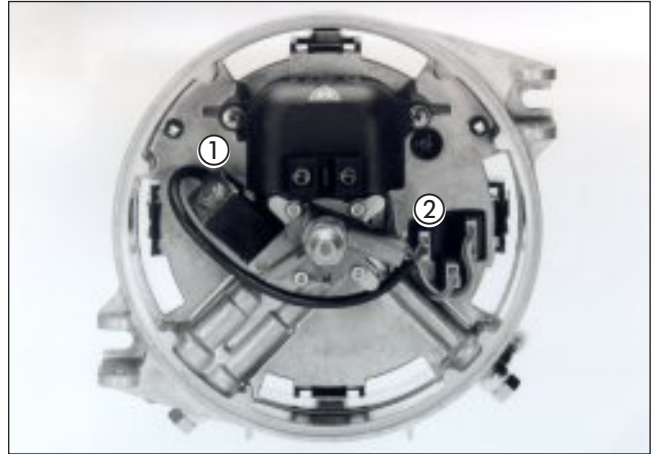
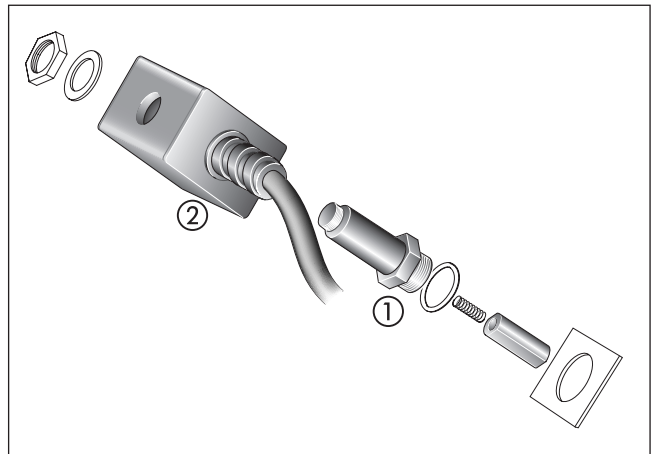

Figure 10

- ① Solenoid valve
- ② Connection of the "solenoid valve" cable loom at control box, slot "D"

Testing the solenoid valve using the burner tester

- Disconnect all connectors from the control box.
- Connect burner tester.
- Press "MV" button → solenoid valve must click – if not, replace solenoid valve.



Sketch 20

- ① Magnet
- ② Solenoid valve coil

5 Repair instructions



Dismantling the nozzle block (see Figure 11 and 12)

- Remove hood.
- Dismantle the burner.
- Disconnect ignition electrodes from ignition unit.
- Undo fuel nozzle from the nozzle block, press against the nozzle block with a wrench.
- Pull fuse clip (KL fuse) from nozzle block.
- Remove baffle plate.
- Disconnect cable loom from control box, slot "F".
- Dismantle nozzle block.

Only for nozzle block made of brass

- Remove split rivet from the nozzle block (heating cartridge holder).
- Pull heating cartridge out of the nozzle block.
- Undo temperature switch (if installed) from the nozzle block.
- If necessary check the heating cartridge (see below).

Please note!

- When installing the heating cartridge, insert the split rivet back in the nozzle block.
- Tightening torque for temperature controller $2.8 +1$ Nm.
- When installing the fuel nozzle do not touch the nozzle opening.
- After installing the fuel nozzle, check the position of the ignition electrodes, adjust if necessary.
- Tightening torque for fuel nozzle:
 - for nozzle block made of brass $16 +1$ Nm.
 - for nozzle block made of plastic $2 +0.5$ Nm.

Functional check of the heating cartridge

- Connect ohmmeter at 2-pin push-on sleeve housing and behind the temperature switch (if installed) → if measured value $5 - 10 \Omega$, heating cartridge is ok, if not replace heating cartridge.

Nozzle block made of brass without temperature switch

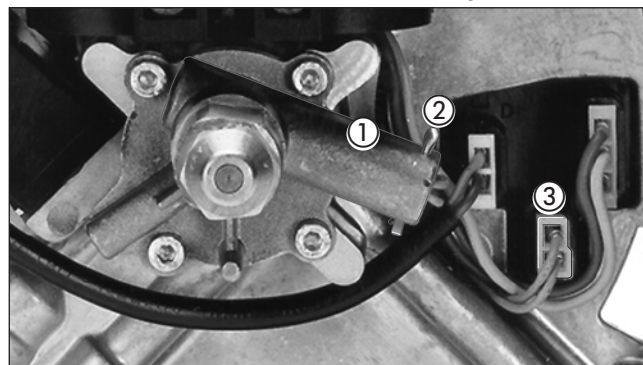

Figure 11

- ① Heating cartridge – installed in nozzle block
- ② Split rivet for heating cartridge
- ③ Connection of the "heating cartridge" cable loom at control box, slot "F"

Nozzle block made of brass with temperature switch (in Hydronic 24 only)

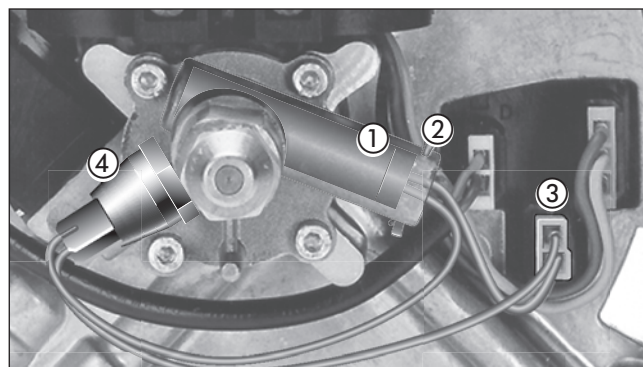
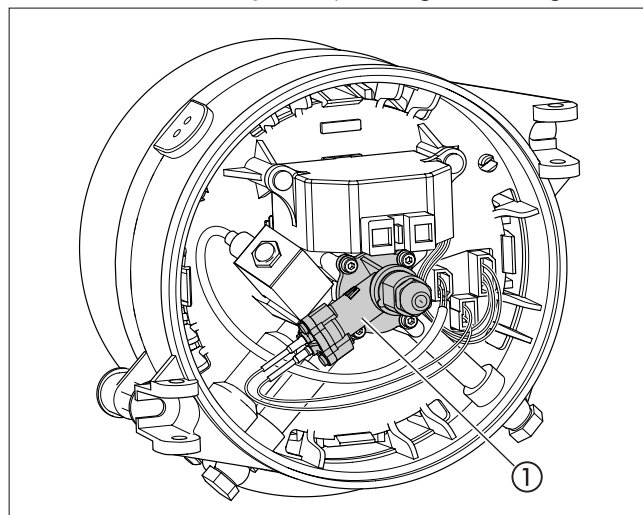

Figure 12

- ① Heating cartridge – installed in nozzle block
- ② Split rivet for heating cartridge
- ③ Connection of the "heating cartridge" cable loom at control box, slot "F"
- ④ Temperature switch

Nozzle block made of plastic (with integrated heating element)



Sketch 21

- ① Nozzle block made of plastic

5 Repair instructions

Dismantling the flame tube (see Figure 13 and Sketch 22)

- Remove hood.
- Dismantle the burner.
- Remove flame tube from the heat exchanger.

Please note!

When installing insert the detent of the flame tube in the groove of the heat exchanger.



Figure 13

- ① Flame tube
- ② Detent on flame tube
- ③ Heat exchanger

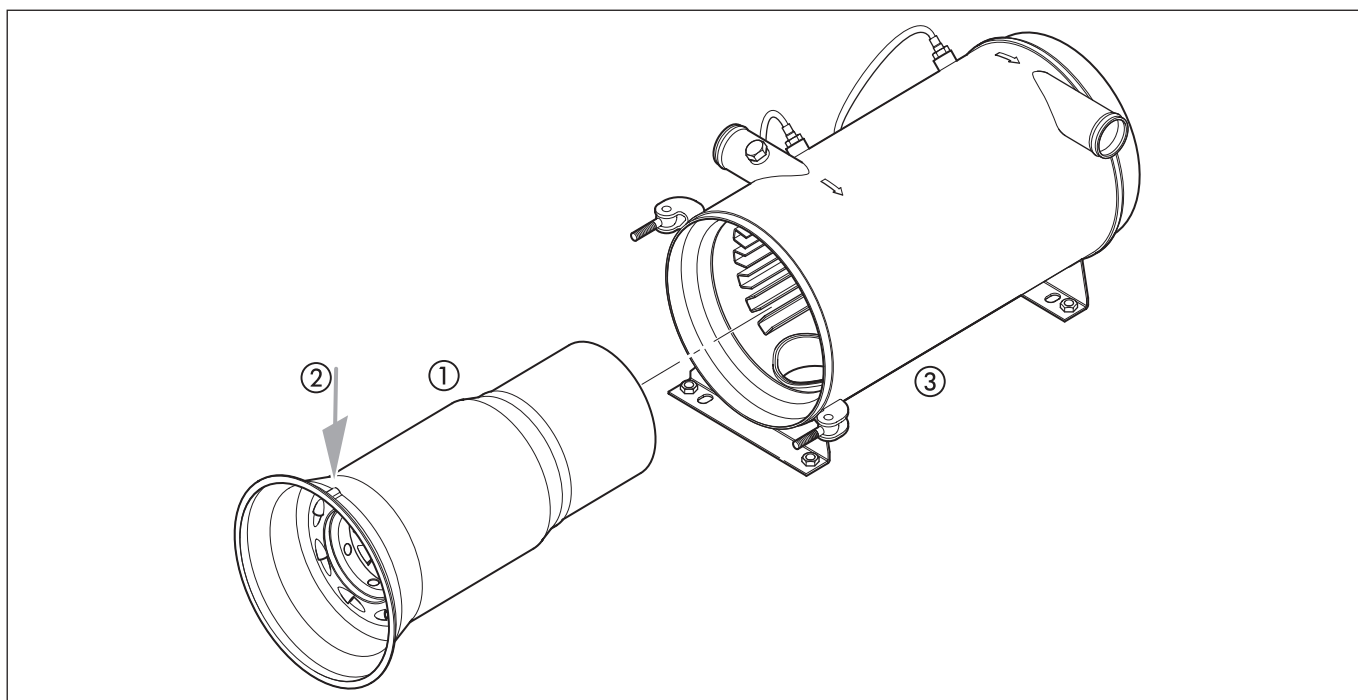

Sketch 22

- ① Flame tube
- ② Detent on flame tube
- ③ Heat exchanger

5 Repair instructions

Dismantling the temperature sensor and overheating sensor (see Figure 14 and Sketch 23)

- Remove hood.
- Dismantle the burner.
- Undo impeller in anti-clockwise direction, at the same time pressing against the motor shaft with a screwdriver.

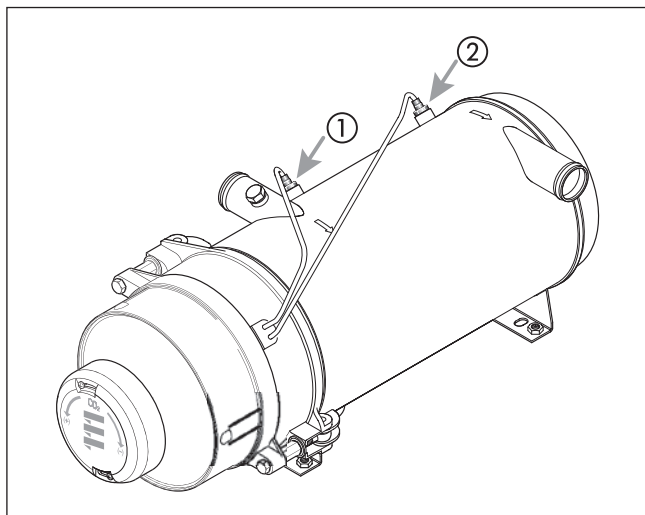

Sketch 23

- ① Temperature sensor
- ② Overheating sensor

- Disconnect temperature and overheating sensor connectors at control box.
- Undo temperature sensor and overheating sensor from the heat exchanger.

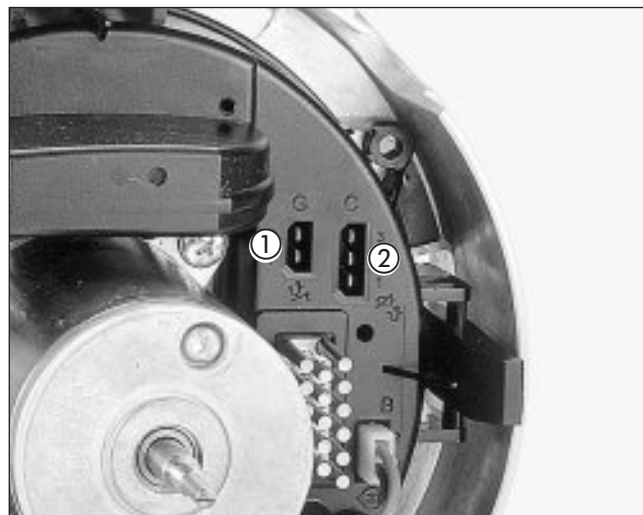

Figure 14

- ① Control box – slot "G" for temperature sensor
- ② Control box – slot "C" for overheating sensor

Resistance values for temperature sensor and overheating sensor (see Sketches 29 and 30)

Test the temperature sensor and the overheating sensor with a digital multimeter and compare the values with the diagram or the characteristic values table.

If the measured values do not match the diagram or the characteristic values table, then replace the temperature sensor or the overheating sensor.

Check for earth short:

There must be no electrical connection between the sensor connections and the housing.

Resistance value must be ∞ .

Characteristic values table – temperature sensor (PTC)

Temp. [°C]	Resistance value [Ω]	all. deviation [$\pm\Omega$]
- 40	567	18
0	815	15
25	1000	12
40	1122	16
60	1299	23
80	1490	30
100	1696	44
120	1915	52
130	2023	62

Diagram - temperature sensor (section)

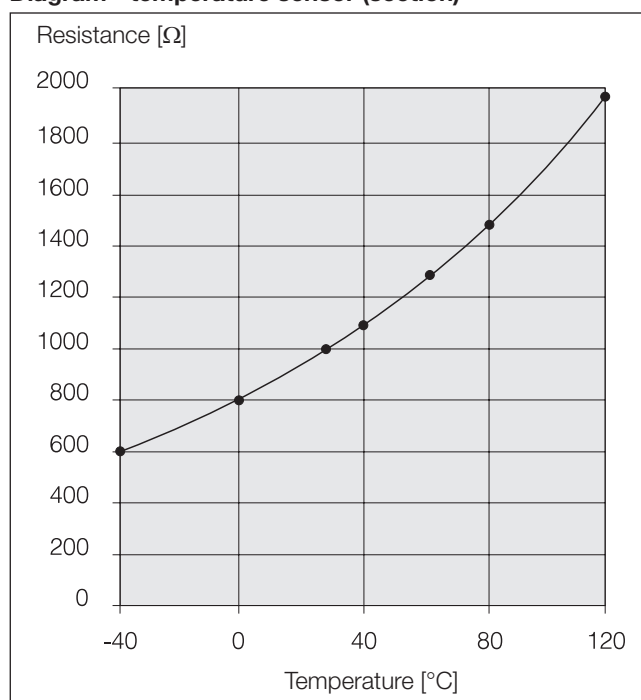

Sketch 24

5 Repair instructions

Characteristic values table – overheating sensor (NTC)

Temp. [°C]	Resistance value [Ω]	all. deviation [$\pm\Omega$]
- 40	3 492 000	324 600
0	337 933	21 560
25	103 517	5 000
40	55 143	3 130
60	25 950	1 727
80	13 118	995
100	7 099	597
120	4 069	374
130	3 135	300
150	1 917	199
180	981	115
200	668	85

Diagram - overheating sensor (section)

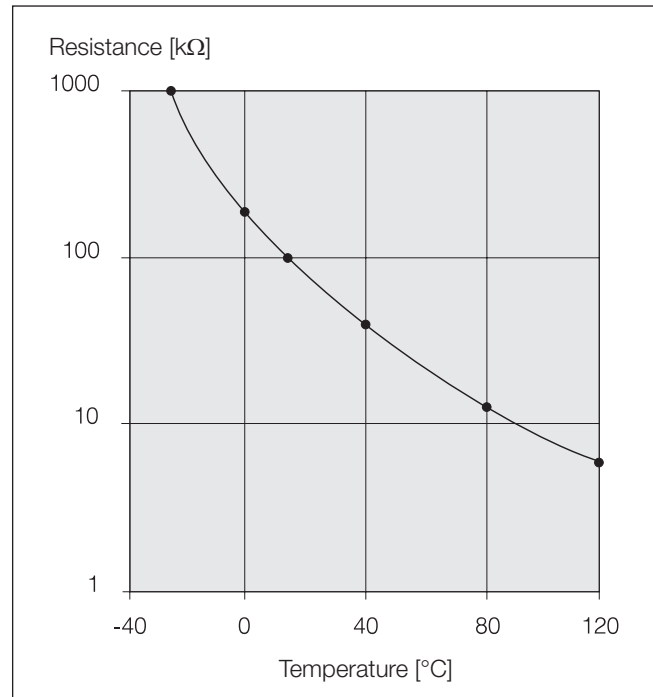

Sketch 25

5 Repair instructions

Dismantling the gauze fuel filter (see Figure 15)

- Remove hood.
- Dismantle the burner.
- Undo the banjo bolt and the ring connector from the fuel flow line at the burner.
- Undo the gauze fuel filter from the burner housing, clean or replace.



Danger!

Risk of fire, explosion and poisoning!

- Caution when handling fuel.
- Avoid naked flames when handling fuel.
- Do not smoke, this also applies where fuel is only noticed by its characteristic odour.
- Do not inhale fuel fumes.
- When dismantling the fuel flow line, collect any escaping fuel.

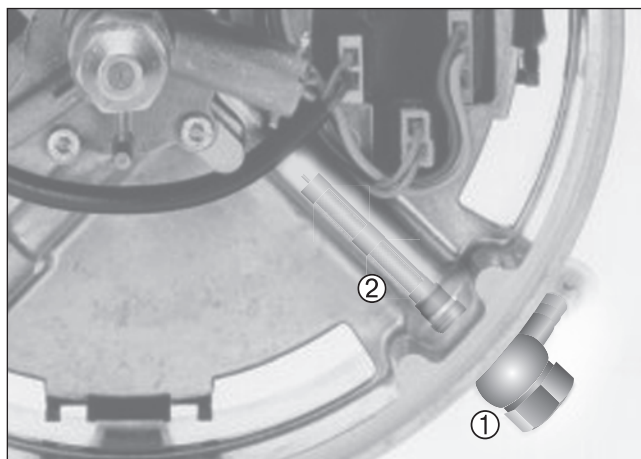

Figure 15

- ① Banjo bolt and ring connector of the fuel flow line
- ② Gauze fuel filter

Notes on the fuel flow rate and the pressure in the fuel system

Precise checking of the fuel flow rate is not possible.

If necessary the combustion can be checked by checking the CO₂ content in the exhaust.

If it is necessary to change the combustion air set in the factor (CO₂ content), this can be achieved by turning the adjusting cap (see page 38).

To ensure perfect function of the fuel pump you must ensure that the partial vacuum in the fuel system does not become too large (see diagram).

Functional performance of the heater depending on the underpressure in the fuel system

In order to ensure the fuel pump works properly, it is necessary to ensure that the underpressure in the fuel system is not too high (see table).

	Fuel pressure (P) Heater inlet	Fuel pressure (P) Filter inlet
Preferred range *	min -0.3 bar	min -0.2 bar
Allowable range **	-0.45 bar to -0.3 bar	-0.35 bar to -0.2 bar
Critical range ***	-0.55 bar to -0.45 bar	-0.45 bar to -0.35 bar
Heating mode not possible	< -0.55 bar	< -0.45 bar

* Range for design of the fuel supply.

** Over the operating period the counterpressure in the fuel supply can increase as a result of deposits (filter clogs up).

*** Heater becomes susceptible to faults (gas bubble formation / fault code 52, 54).

5 Repair instructions

Measuring the CO₂ content in the exhaust



Danger!

Risk of injury, fire and poisoning!

- The heater must not be operated in closed rooms such as garages or workshops without an exhaust extraction system.
- Do not operate the heater if the burner is dismantled.

Please note!

- It is necessary to measure the CO₂ content, if necessary adjust the combustion air:
 - after repairs to heater (functional check).
 - if combustion is not working properly.
 - after replacing the fuel nozzle.

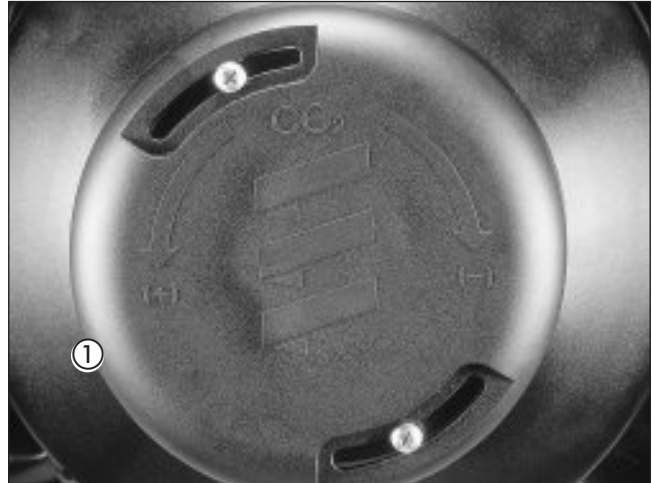

Figure 16

- ① Adjusting cap

Measurement

Measure the CO₂ content of the heater in the vehicle ready for service.

In order to carry out a correct measurement of the CO₂ content the heater must have reached its operating temperature. Measure the CO₂- content using a CO₂ indicator, to this end, read and follow the manufacturer's instructions.

Adjusting the combustion air (see Figure 16)

- Undo the adjusting cap screws.
 - If the CO₂ content is less than 9 % by vol, turn the adjusting cap to the left (CO₂ +).
 - If the CO₂ content is higher than 11 % by vol, turn the adjusting cap to the right (CO₂ -).
- Retighten the adjusting cap.
- If proper adjustment of the CO₂ content is no longer possible:
 - Check the burner for damage.
 - Check the speed of the electric motor.
 - Replace fuel nozzle.



5 Repair instructions

Dismantling the water pump (standard design)

(see Sketch 27)

- Undo screws from pump housing and remove the pump housing.
- Undo locknut and remove the impeller.
- Pull the mechanical seal and stationary seal ring off the motor shaft.
- Undo screws from pump flange and remove the pump flange.
- Replace defective parts.

Please note!

- Before installation, clean mechanical seal and stationary seal ring with a dry cloth.
- The sliding surfaces must be free of grease and dust.
- Always renew the O-ring.
- Component part No. see spare parts list.

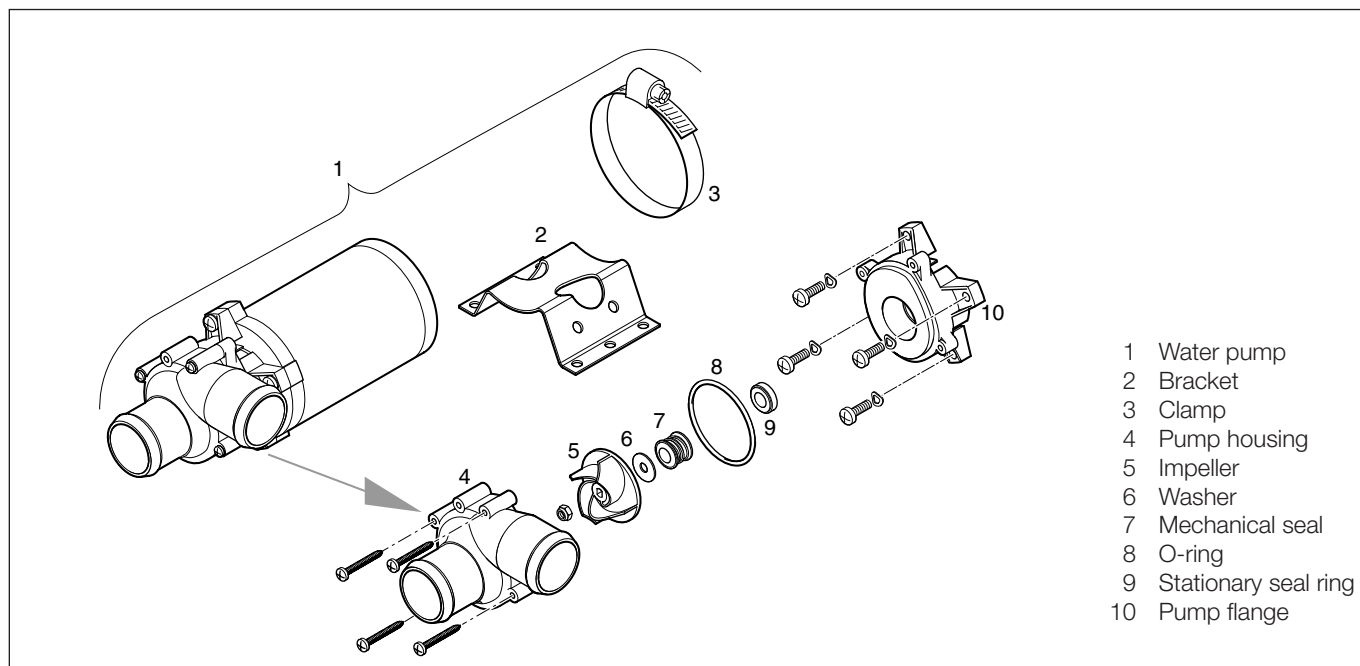

Sketch 27

"Bus 2000" water pump (see Sketch 28)

The "Bus 2000" water pump is maintenance free. If damaged, replace the complete water pump.

Please note!

Component part No. of attachments, see spare parts list.

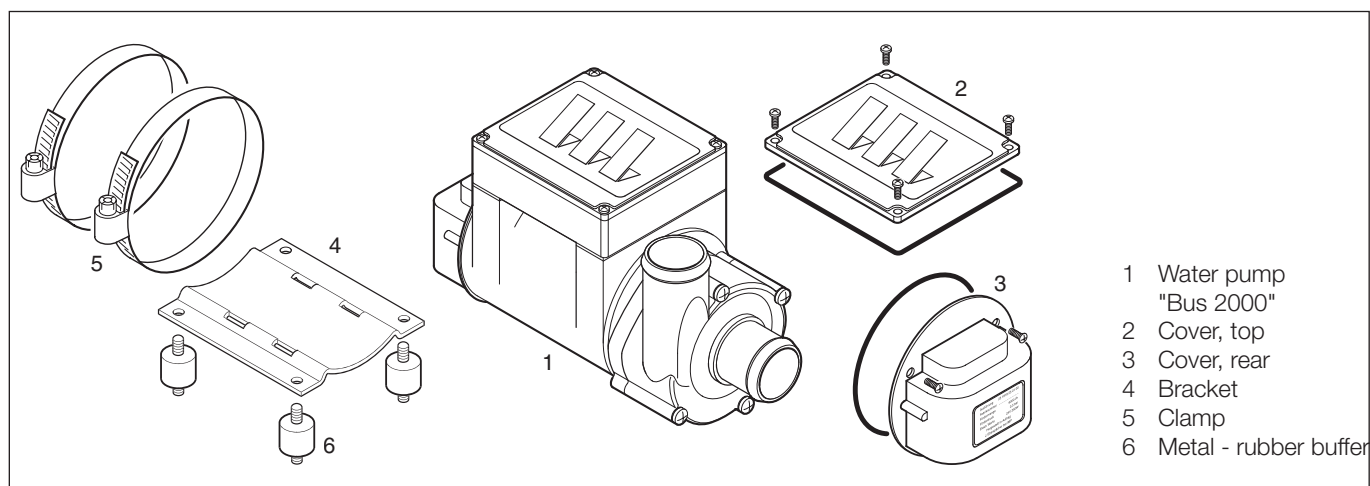

Sketch 28

5 Repair instructions

Dismantling the *FLOWTRONIC* 5000 water pump

(see Sketch 29)

- Undo screws on pump cover.
- Remove the pump cover and check for damage.
- Undo nut while holding on to the impeller, unscrew from the motor shaft and dispose of the nut.
- Pull the impeller and spacer off the motor shaft and dispose of them.
- Undo and dispose of screws with spring lock washers on pump housing.
- Pull the pump housing with mechanical seal and stationary seal ring off the motor shaft and dispose of them.
- Remove the washer and if applicable splash guard off the motor shaft and dispose of the washer.
- Check motor for smooth and easy movement and examine for damage, unbalance and noise generation.

Please note!

- Before installation, clean mechanical seal and stationary seal ring with a dry cloth.
- The sliding surfaces must be free of grease and dust.
- Always renew the O-ring.
- Component part No. see spare parts list.

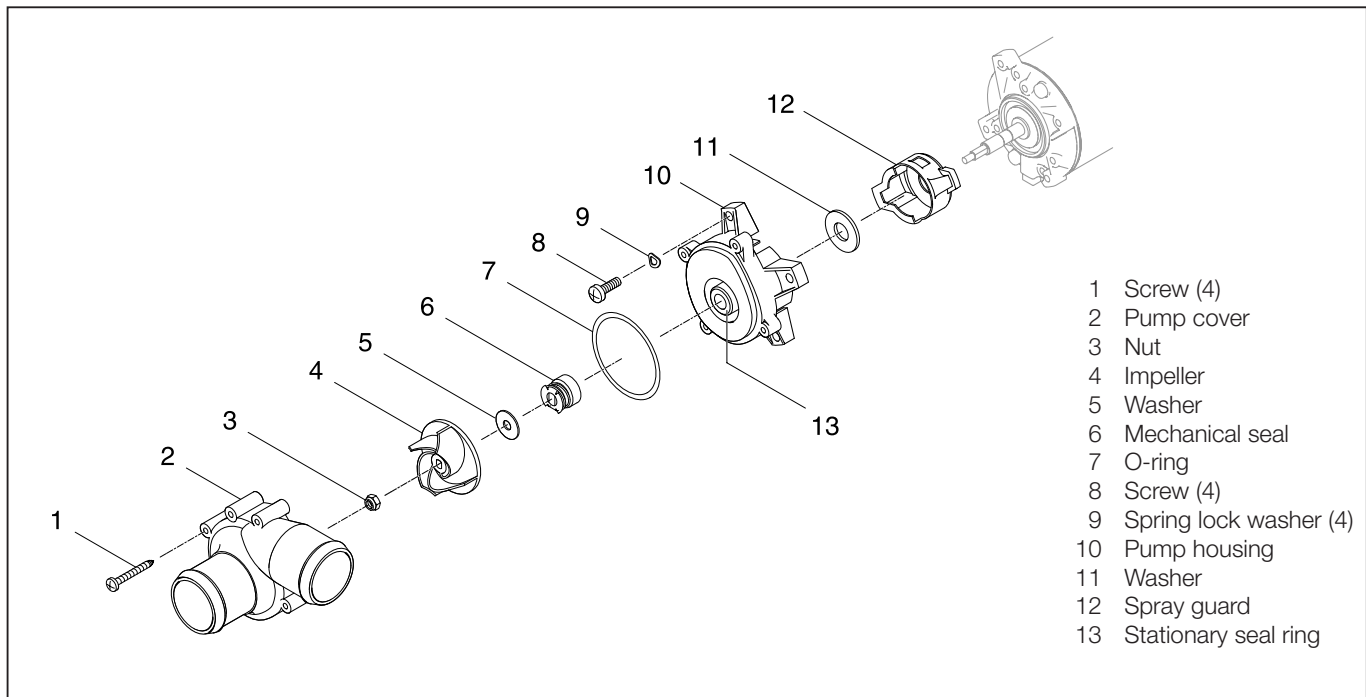

Sketch 29



6 Circuit diagram

Heater circuit diagram – part 1

Hydronic 16 – 24 volt 25 2165 01 00 00 (with temperature switch Item 1.4.1)

Hydronic 24 – 24 volt 25 1817 01 00 00 (with temperature switch Item 1.4.1)

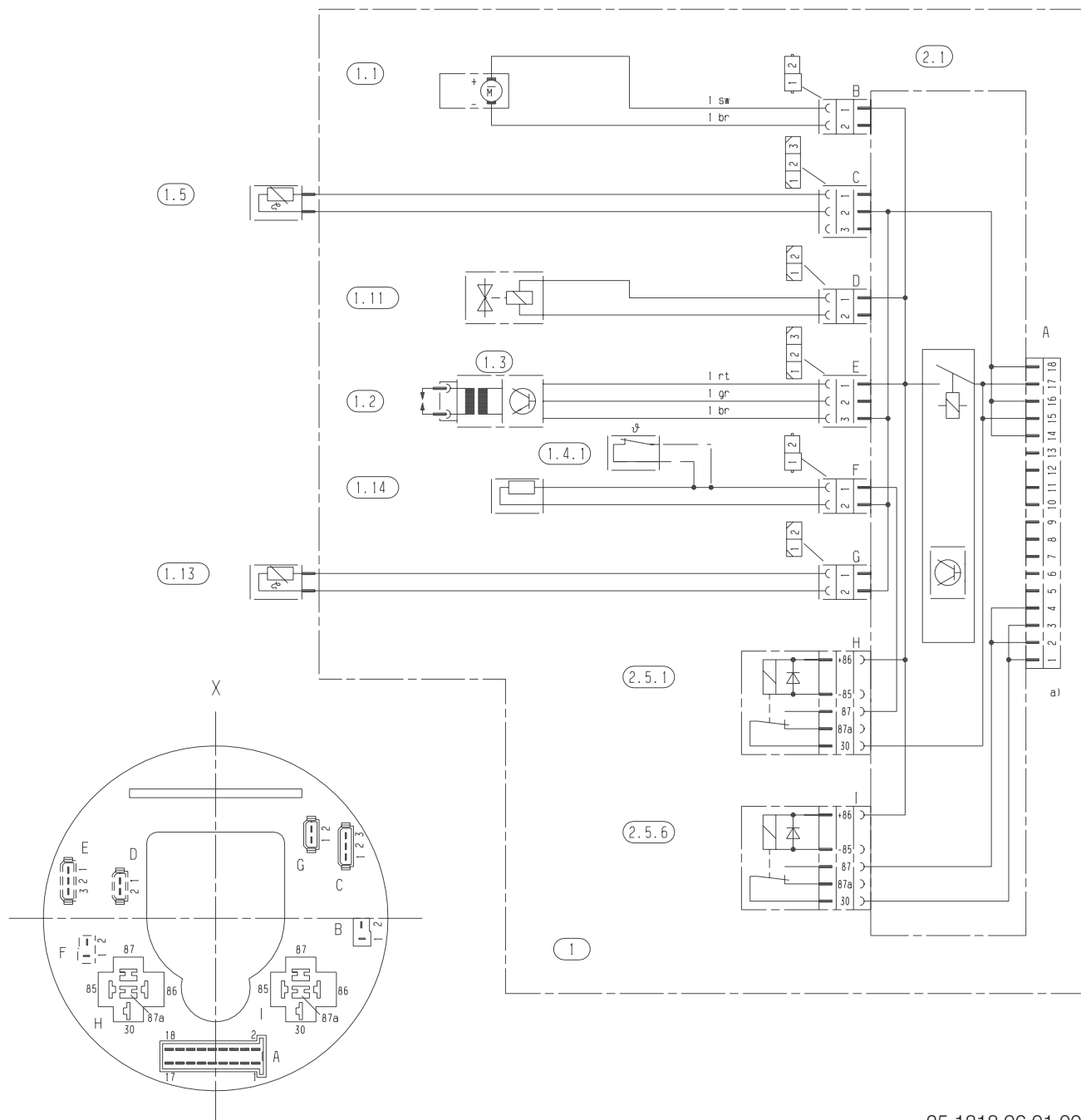

25 1818 96 01 00 C

Parts list

- | | | | | | |
|-------|---|-------|--|----|---|
| 1 | Heater | 1.11 | Fuel solenoid valve | a) | Heater connection |
| 1.1 | Burner engine | 1.13 | Temperature sensor | X | Graphic illustration of the control box from the impeller side |
| 1.2 | Ignition electrode | 1.14 | Heating cartridge for nozzle block heating | | |
| 1.3 | Ignition unit | 2.1 | Control box | | |
| 1.4.1 | Temperature switch in Hydronic 16 / 24 only | 2.5.1 | Relay, heating cartridge | | Connectors and bush housings are shown from the cable inlet side. |
| 1.5 | Overheating sensor | 2.5.6 | Relay, water pump | | |

6 Circuit diagram

Heater circuit diagram – part 1

Hydronic 16 – 24 volt 25 2165 01 00 00 (without temperature switch)
 Hydronic 24 – 24 volt 25 1817 01 00 00 (without temperature switch)
 Hydronic 30 – 24 volt 25 1818 01 00 00
 Hydronic 35 – 24 volt 25 1819 01 00 00

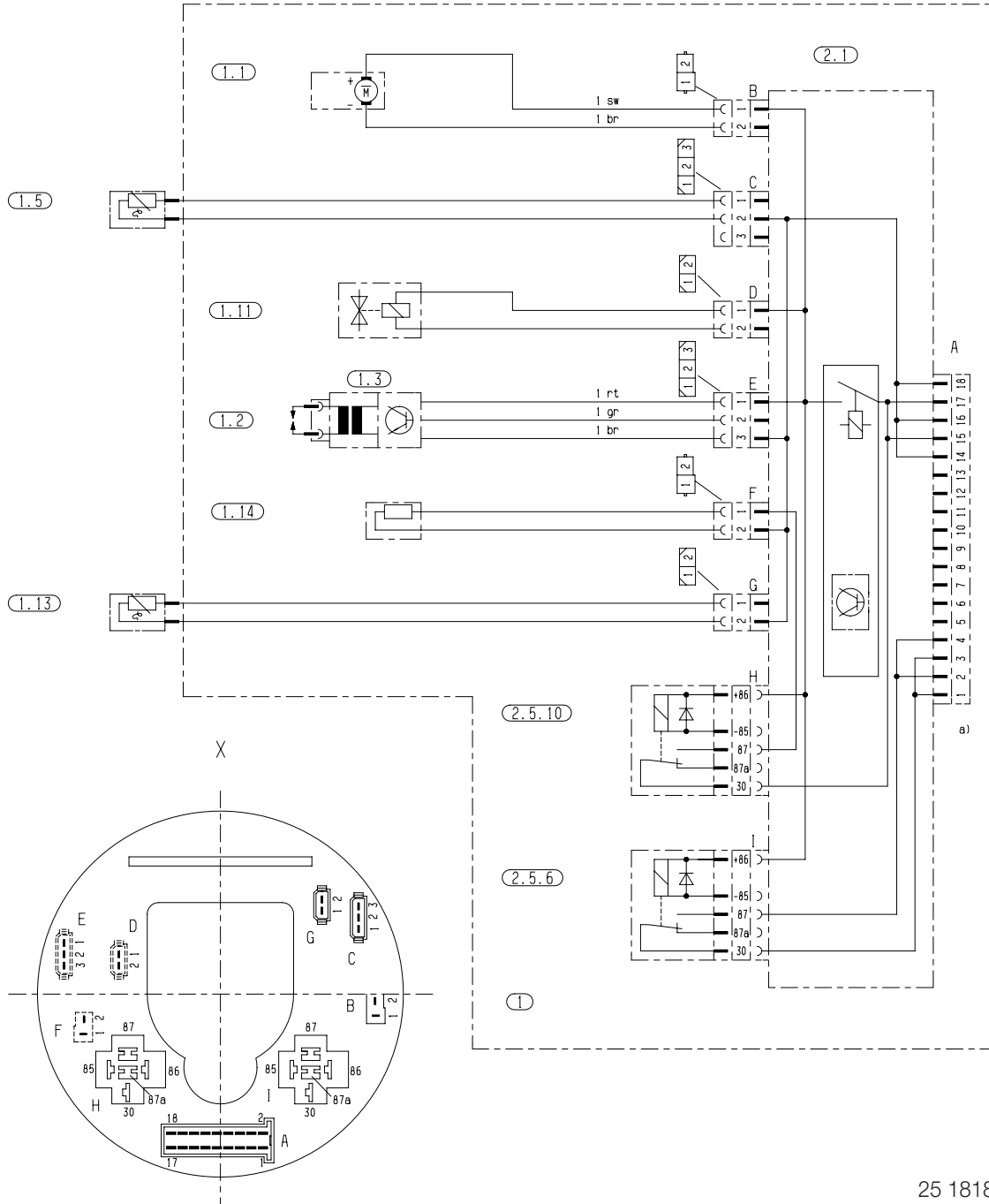

25 1818 00 96 01 D

Parts list

- | | | | | | |
|------|---------------------|--------|--------------------------------------|----|---|
| 1 | Heater | 1.13 | Sensor, internal control temperature | a) | Connection, control unit |
| 1.1 | Burner engine | 1.14 | Heating element for fuel nozzle | X | Graphic illustration of the control box from the impeller side |
| 1.2 | Ignition electrodes | | | | |
| 1.3 | Ignition unit | | | | |
| 1.5 | Overheating sensor | 2.1 | Control box | | Connectors and bush housings are shown from the cable inlet side. |
| 1.11 | Fuel solenoid valve | 2.5.6 | Relay, water pump | | |
| | | 2.5.10 | Relay, heating cartridge | | |



6 Circuit diagram

Heater circuit diagram – part 2

with water pump (standard design) and Bus 2000 water pump

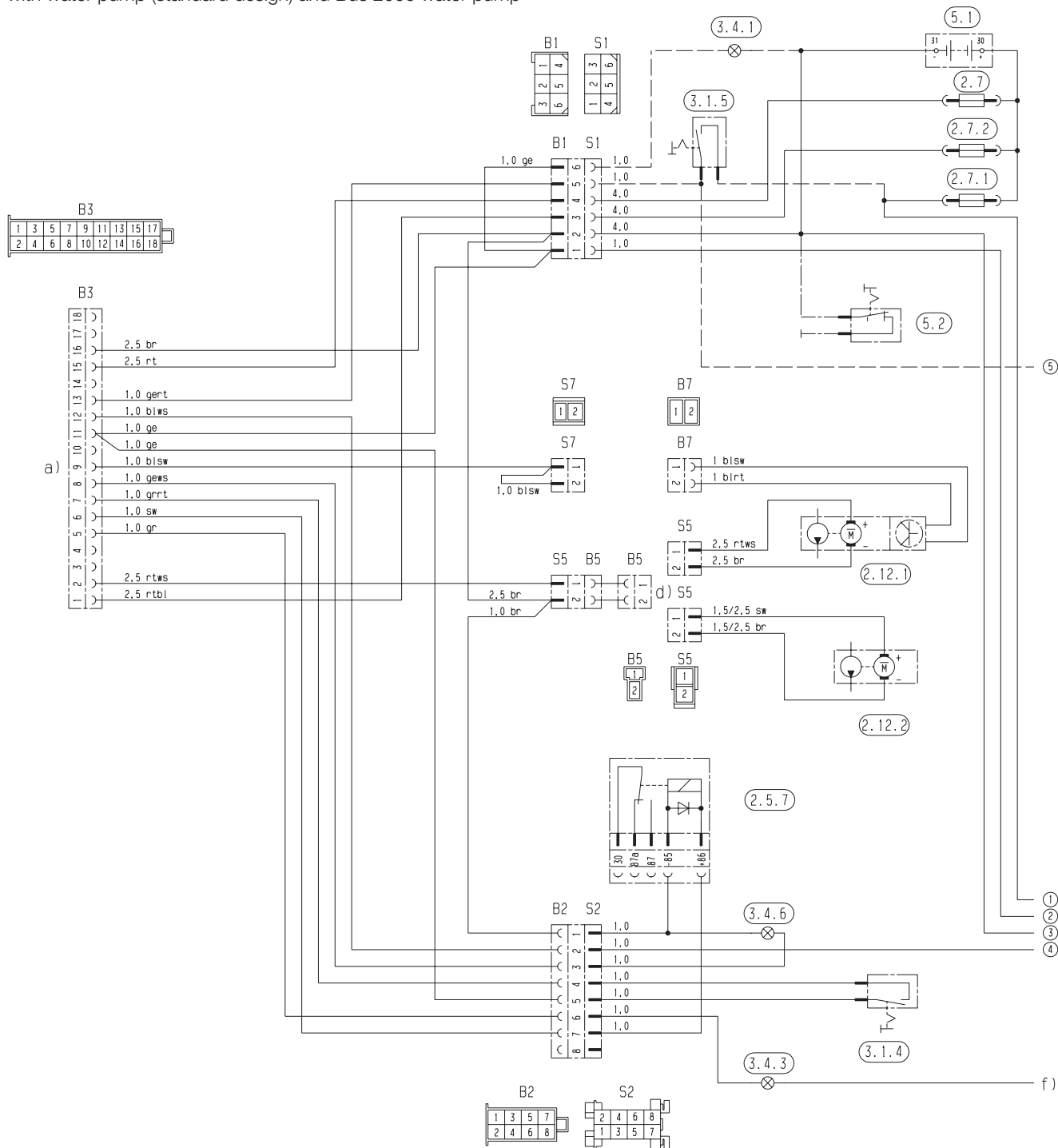

25 1818 97 01 00 E

Parts list

2.5.7	Relay for control e.g. vehicle blower	3.1.4	Switch, temperature drop	a)	Heater connection
2.7	Main fuse 15 A	3.1.5	Switch, water pump	d)	optionally 2.12.1 or 2.12.2
2.7.1	Fuse, actuation 5 A	3.4.1	Operating display / flame indicator	f)	If using 3.2.6
2.7.2	Fuse, water pump 15 A	3.4.3	Fault code display		optionally terminal 15 or
2.12.1	Bus 2000 water pump	3.4.6	Combustion indicator light		terminal 30 - otherwise start
2.12.2	Water pump (standard design)	5.1	Battery		positive (cable 1 ² yellow)
		5.2	Battery disconnect		

6 Circuit diagram

Heater circuit diagram – part 3

with FLOWTRONIC water pump

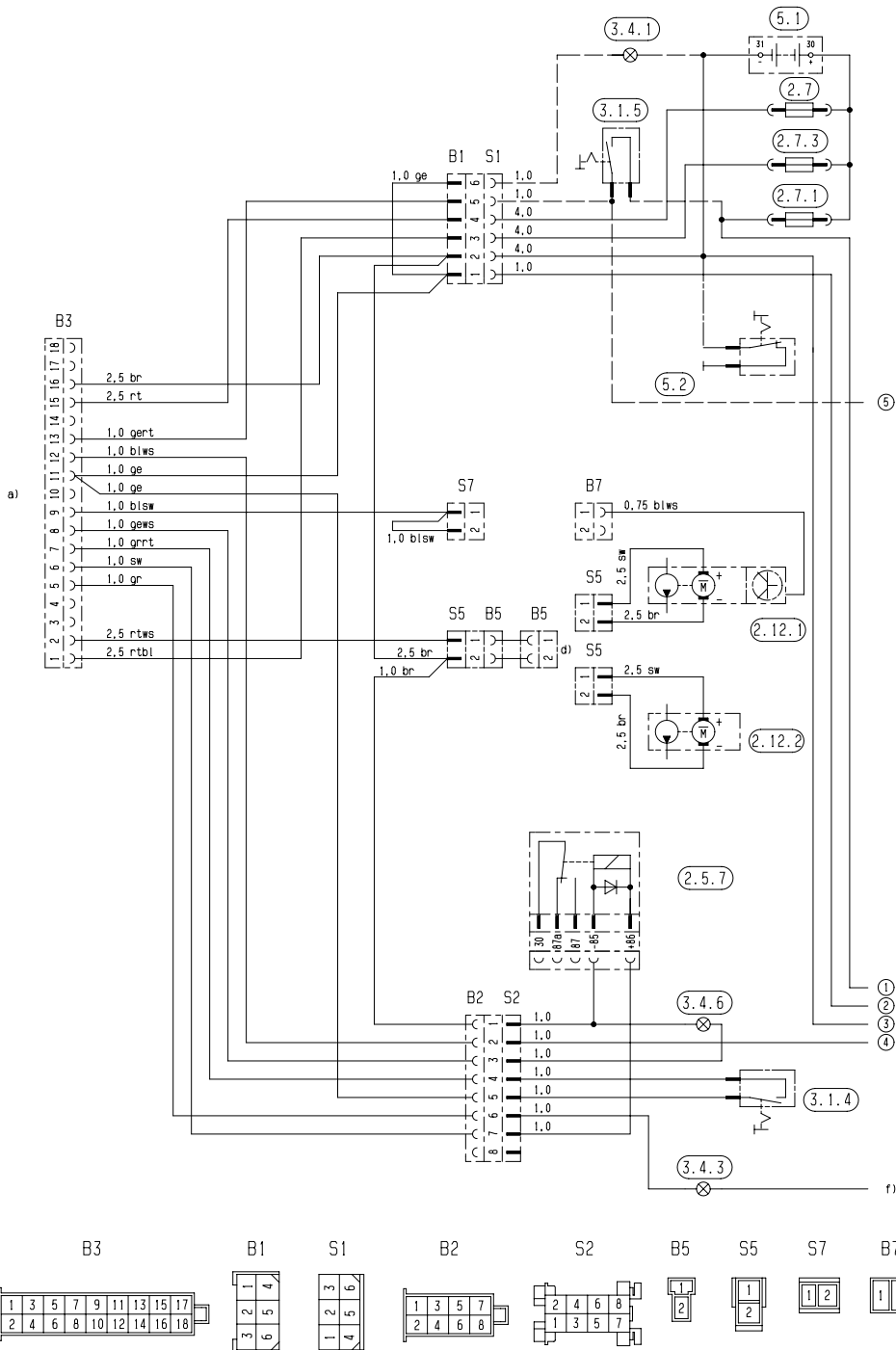

Parts list

- 2.5.7 Relay for control, vehicle blower
- 2.7 Main fuse 15 A
- 2.7.1 Fuse, actuation 5 A
- 2.7.3 Fuse, water pump 15 A
- 2.12.1 FLOWTRONIC 6000S water pump
- 2.12.2 FLOWTRONIC 5000 / 5000S water pump

- 3.4.1 Switch on check
- 3.4.3 Fault indicator light
- 3.4.6 Combustion indicator light

- 3.1.4 Switch, temperature drop
- 3.1.5 Switch, water pump

- 5.1 Battery
- 5.2 Battery disconnect
- a) Heater connection
- d) optionally 2.12.1 or 2.12.2
- f) If using 3.2.6 optionally terminal 15 or terminal 30 – otherwise start positive (cable 1² yellow)

25 1818 00 97 01 F

6 Circuit diagram

Circuit diagram for control units

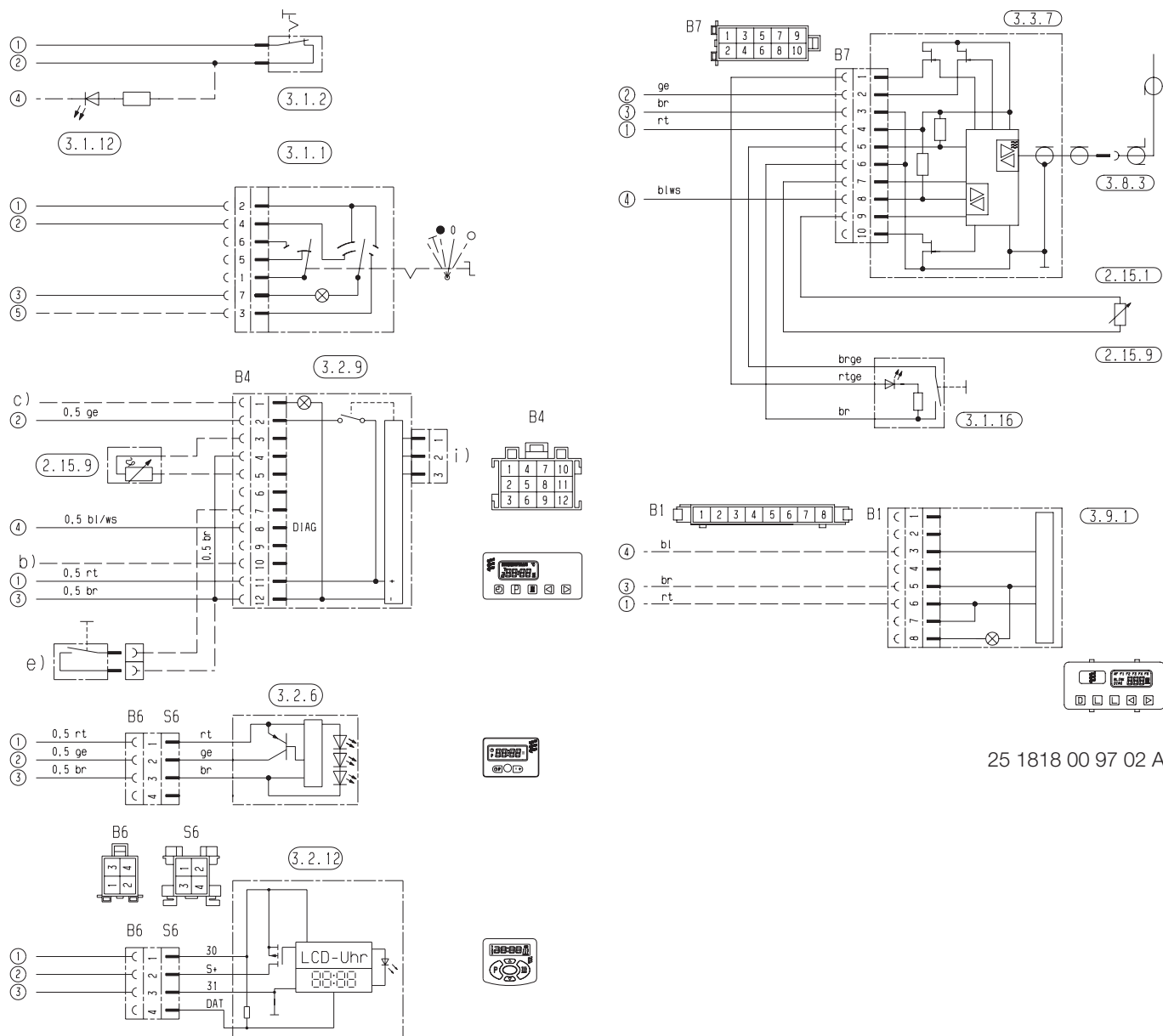

25 1818 00 97 01 E

25 1818 00 97 02 A

Parts list

- 2.15.1 Temperature sensor (room temperature)
- 2.15.9 Temperature sensor (outside temperature)
- 3.1.1 Universal switch
- 3.1.2 Switch, heat, continuous operation
- 3.1.12 Fault code query
- 3.1.16 Button, radio remote control
- 3.2.9 Module timer
- 3.2.12 Timer, mini (12 / 24 volt)
- 3.3.7 TP5 radio remote control
- 3.8.3 Antenna
- 3.9.1 Diagnostic unit, JE diagnosis

- b) Connect to +15
- c) Lighting, terminal 58
- e) External "ON / OFF" key (optional)
- i) Connection, radio remote control

Insulate unused cable ends.

Connectors and bush housings are shown from the cable inlet side.

6 Circuit diagram

Circuit diagram for control units

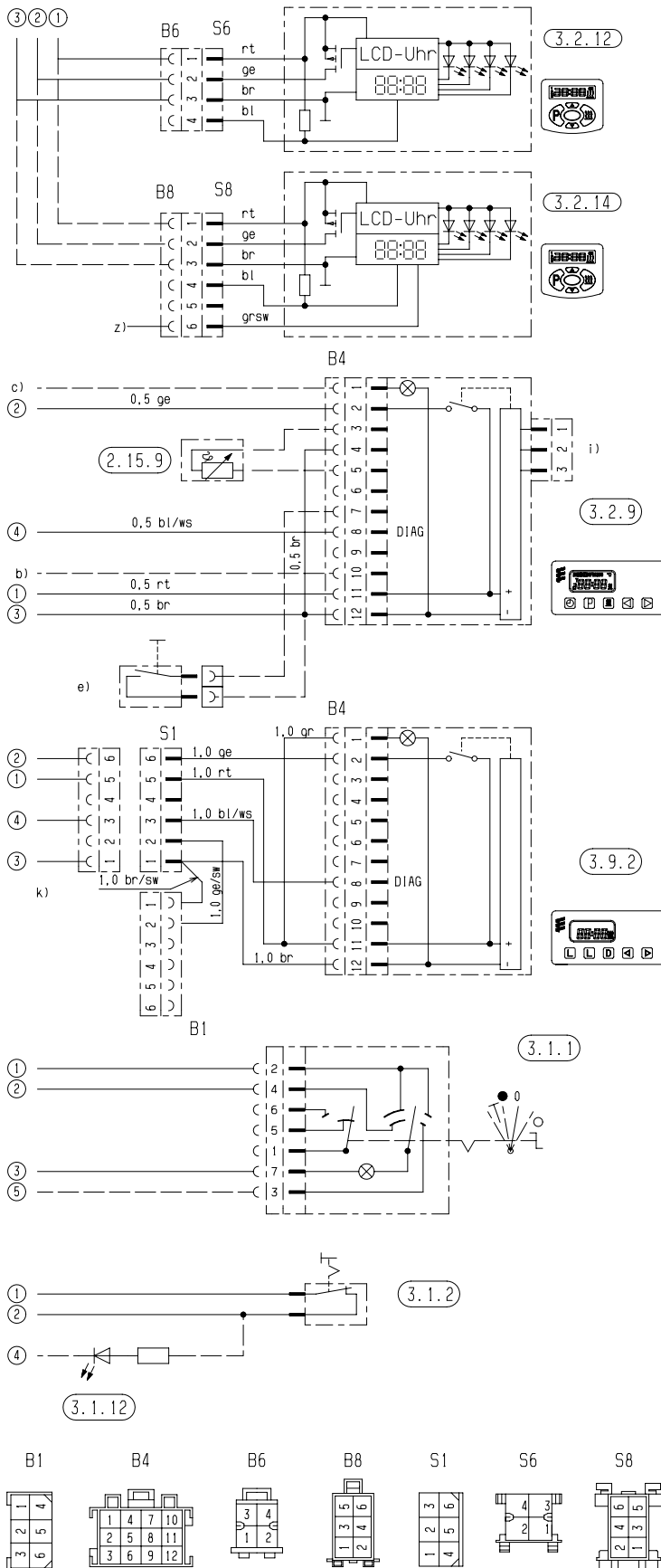

Parts list

2.15.9 Temperature sensor (outside temperature)

3.1.1 Universal switch

3.1.2 Switch, heat, continuous operation

3.1.12 Fault code query

3.2.9 Module timer

3.2.12 Timer, mini (12 / 24 volt)

3.2.14 Timer, mini, lighting (12 / 24 volt)

3.9.2 Diagnostic unit

b) Connect to +15

c) Lighting, terminal 58

e) External "ON / OFF" key (optional)

i) Connection, radio module

k) Not included in scope of supply of 3.9.2

z) Terminal 58 (lighting)

Insulate unused cable ends.

Connectors and bush housings are shown from the cable inlet side.

25 1818 00 97 01 F



6 Circuit diagram

Parts list for circuit diagram - EasyStart control units

- 2.15.1 Temperature sensor (room temperature)
(included in scope of supply for EasyStart R+,
optional for EasyStart T and EasyStart R)
- 2.15.9 Outside temperature sensor (optional)

- 3.1.7 "OFF" button
- 3.1.9 "Heat / Ventilate" switch
(included in scope of supply for EasyStart T,
optional for EasyStart R)
- 3.1.16 Radio remote control button

- 3.2.15 Timer EasyStart T

- 3.3.9 Radio remote control EasyStart R (stationary unit)
- 3.3.10 Radio remote control EasyStart R+ (stationary unit)

- 3.6.1 Lead harness

- 3.8.3 Antenna

- c) Terminal 58 (lighting)
- d) Parking ventilation with vehicle fan (optional)
- e) Connection, EasyStart T timer
- g) External "ON / OFF" key (optional)

Cable colours circuit diagrams

sw	=	black
ws	=	white
rt	=	red
ge	=	yellow
gn	=	green
vi	=	violet
br	=	brown
gr	=	grey
bl	=	blue
li	=	purple

Connectors and bush housings are shown from the cable inlet side.

Please note!

Circuit diagrams, see pages 48 – 50.

6 Circuit diagram

Circuit diagram, EasyStart R control units

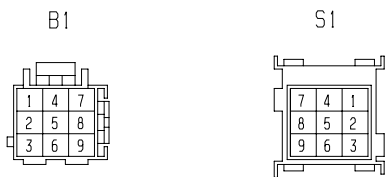
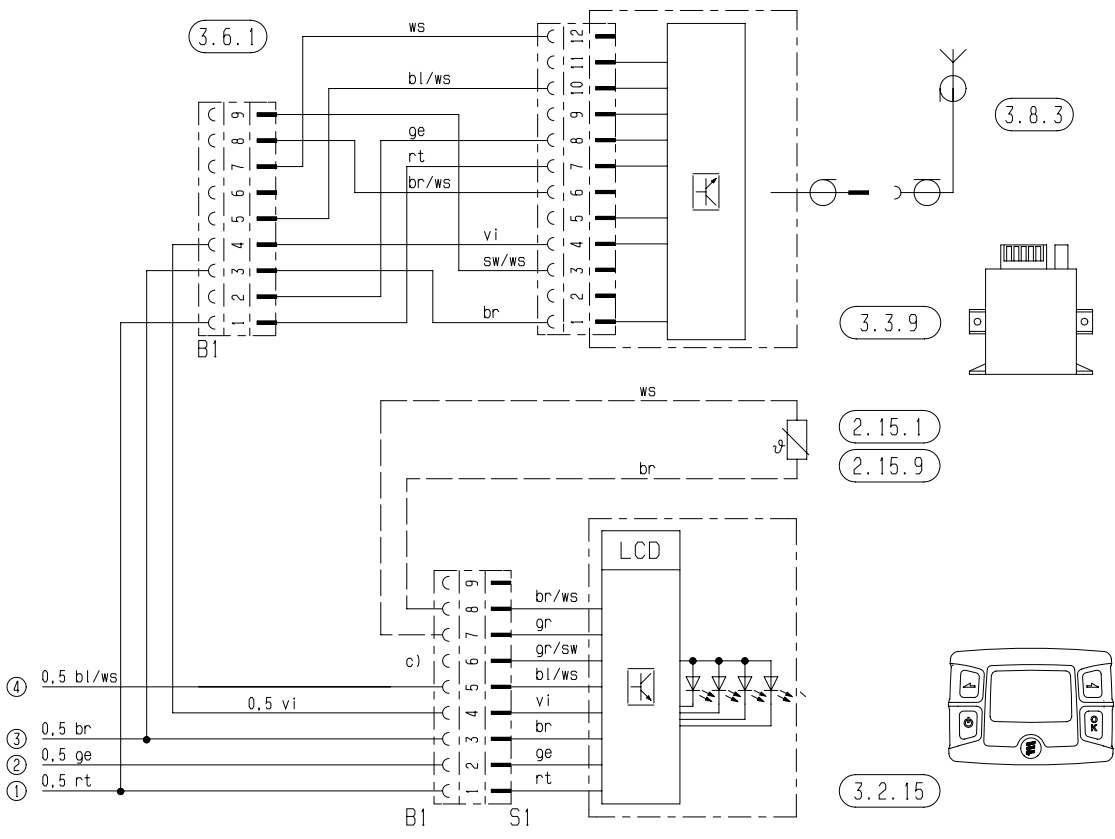
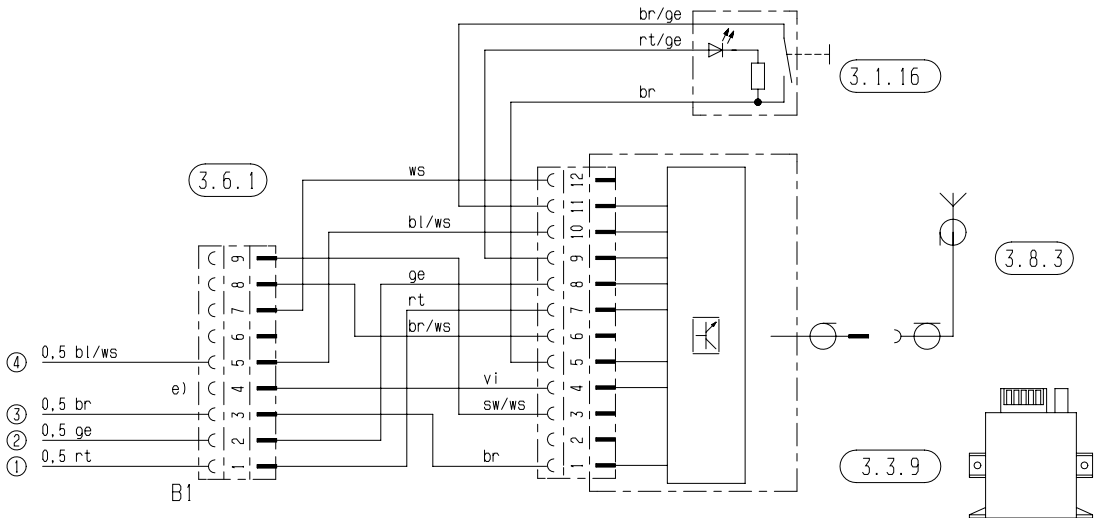



6 Circuit diagram

Circuit diagram, EasyStart R+ control units

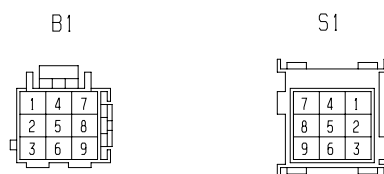
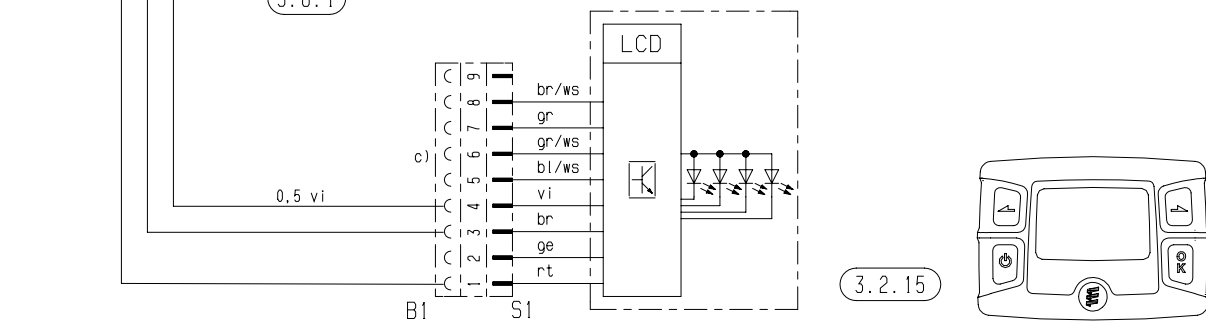
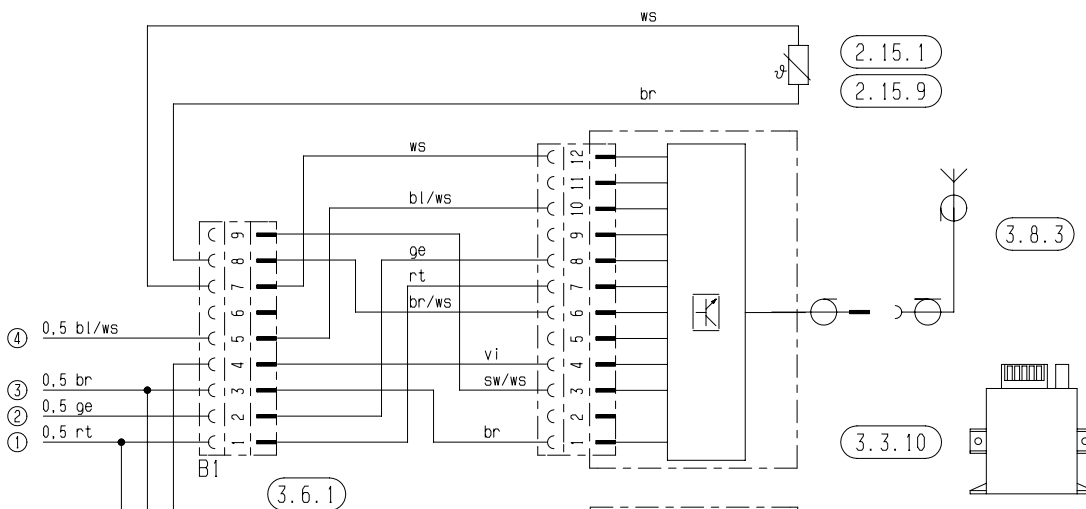
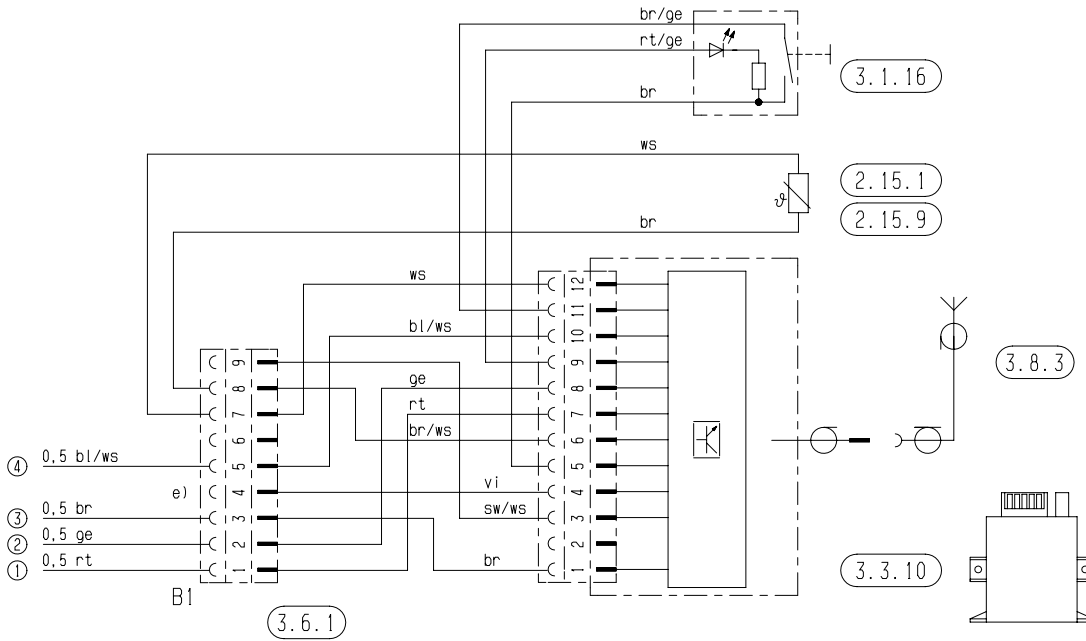

6 Circuit diagram

Circuit diagram, EasyStart T control units

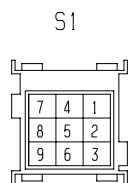
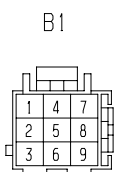
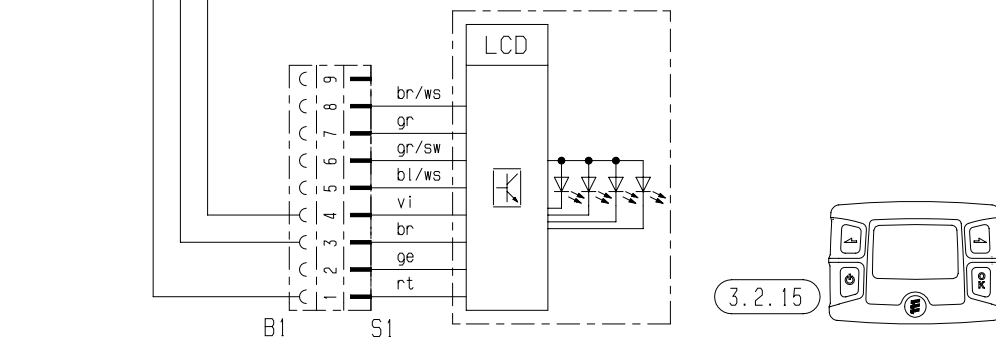
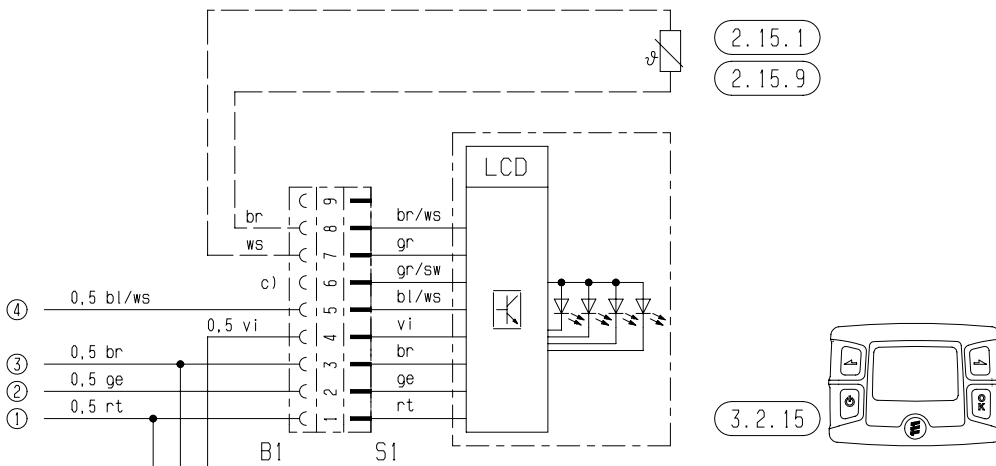
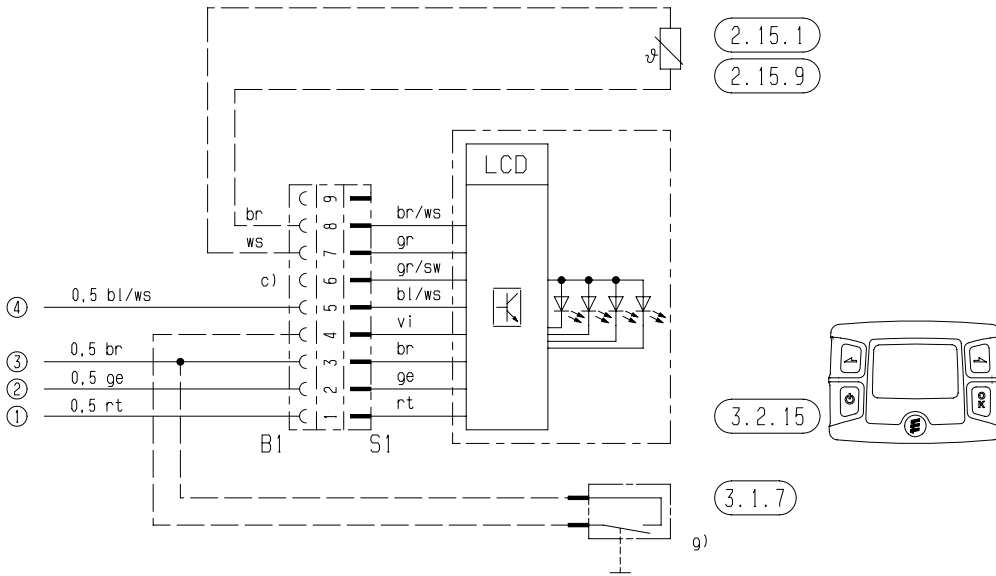



7 Service

Certification

The high quality of Eberspächer's products is the key to our success.

To guarantee this quality, we have organised all work processes in the company along the lines of quality management (QM). Even so, we still pursue a large number of activities for continuous improvement of product quality in order to keep pace with the similarly constantly growing requirements made by our customers.

All the steps necessary for quality assurance are stipulated in international standards. This quality is to be considered in a total sense.

It affects products, procedures and customer / supplier relationships.

Officially approved public experts assess the system and the corresponding certification company awards a certificate.

Eberspächer has already qualified for the following standards:

**Quality management in accordance with
DIN EN ISO 9001:2000 and ISO/TS 16949:1999**

**Environmental management system in accordance with
DIN EN ISO 14001:1996**

Disposal

Disposal of materials

Old devices, defect components and packaging material can all be separated and sorted into pure-grade fractions so that all parts can be disposed of as required in an environment-friendly manner recycled where applicable. Electric motors, control boxes and sensors (e.g. temperature sensors) are deemed to be "electronic scrap".

Dismantling the heater

The heater is dismantled according to the repair stages in the current troubleshooting / repair instructions.

Packaging

The packaging of the heater can be kept in case it has to be sent back.

EC Declaration of Conformity

With regard to the following products

Heater type Hydronic L

we herewith confirm that it conforms with the prime safety requirements stipulated in the directives of the EU Council for harmonisation of the legal regulations of the member states with regard to electromagnetic compatibility (89 / 336 / EEC). This declaration applies to all heaters produced according to the production drawings Hydronic L which are an integral part of this declaration.

The following standards / directives have been used to assess the product with regard to electromagnetic compatibility:

- EN 50081 – 1 Basic form interference emission
- EN 50082 – 1 Basic form of interference immunity
- 72 / 245 / EEC – Modification status 2005 / 83 / EC interference suppression in motor vehicles.

7 Service

List of key words

Keyword	Page
A	
Accident prevention.....	4
Ambient temperature.....	9, 10
AMP release tool.....	27
Assembly drawing.....	25, 26
B	
Burner engine.....	29
Burner start.....	6
Burner tester.....	13
Burner.....	26
C	
Cancelling the control box lock.....	11, 15, 16, 18, 19
Certification.....	51
Characteristic values table.....	35, 36
Circuit diagram.....	41 – 50
CO in the exhaust.....	9
CO ₂ value.....	9, 38
Contents.....	2, 3
Control box.....	26
Control diagram.....	7
Control unit.....	6
Cutaway view.....	5
D	
Declaration of conformity.....	51
Delivery rate.....	10
Description of functions.....	6
Diagnostic system, external.....	13
Diagnostic unit.....	13, 14, 15
Disposal.....	51
E	
EasyStart R+ radio remote control.....	20
EDiTH customer service program.....	16, 17
Electrical power consumption.....	9, 10
Electromagnetic compatibility.....	55
Emergency shutdown.....	8
Environmental protection.....	51
F	
Fault code.....	21 – 24
Fault description.....	21 – 24
Faults.....	11
Flame tube.....	26, 34
Flashing code.....	11, 12
FLOWTRONIC water pump.....	10, 40
Fuel consumption.....	9, 10
Fuel nozzle.....	30
Fuel quantity.....	37
Fuel supply.....	37
Fuel.....	9, 10
Function.....	5 – 8
Functional check.....	27
Functional diagram.....	7
G	
Gauze fuel filter.....	37

Keyword	Page
H	
Heat flow.....	9, 10
Heating cartridge.....	26, 33
Heating element.....	5, 26, 33
Heating medium.....	9, 10
Hood.....	26, 28
I	
Ignition electrodes.....	26, 30
Ignition unit.....	26, 31
Initial commissioning.....	4
Interference suppression class.....	9, 10
Introduction.....	2 – 4
ISO adapter.....	16
L	
Locking the control box.....	11
M	
Minimum flow rate.....	9, 10
Module timer.....	18
N	
Nozzle block - heating cartridge.....	33
O	
Operating instructions.....	6
Operating pressure.....	9, 10
Overheating sensor.....	35, 36
P	
Packaging.....	51
Permissible ambient temperature.....	9, 10
Picture symbols.....	4
Power consumption.....	9, 10
Pressure loss characteristic curve.....	10
Product information.....	9, 10
Protection.....	9, 10
Pumping characteristic curve.....	10
R	
Radio remote control TP 5.....	19
Rated voltage.....	9, 10
Remedial action.....	21 – 24
Repair instructions.....	25 – 40
Representatives abroad.....	52, 53
S	
Safety devices.....	8
Safety Instructions.....	4
Solenoid valve.....	32
Spare parts list.....	26
Structure of the heater.....	6
Switching off.....	6
Switching on.....	6
T	
Technical data.....	9, 10
Temperature control values.....	7
Temperature sensor.....	35
Temperature switch.....	26, 33
Test equipment.....	13
Troubleshooting.....	11 – 24



7 Service

List of key words

Keyword	Page
V	
Voltage limit	9, 10
Voltage	9, 10
W	
Water pump, Bus 2000	39
Water pump, normal design.....	39
Weight.....	9, 10

www.eberspaecher.com

J. Eberspächer
GmbH & Co. KG
Eberspächerstraße 24
D-73730 Esslingen
Phone 0711 939-00
Telefax 0711 939-0643
info@eberspaecher.com

